



# Assembly and Installation

## Guide for AX550 Bi-fold Doors

---

### **STOP! IMPORTANT!**

It is imperative that you carefully review and understand these instructions and all drawings supplied prior to installation of the Milgard AX550 Bi-fold Door System (the "Product"). Responsibility for product selection and installation rests with the owner, architect and installation contractor. Do not proceed with installation unless all factors necessary to properly integrate the Product into a building's water management system have been addressed.

**Milgard makes no representation or warranty that these recommendations include all information necessary to ensure proper integration into every building. State and local code requirements may impose different or additional demands which could supersede, supplement and/or modify these recommendations. For additional guidance regarding installation of the Product refer to applicable industry standards.**

**(E.g. AAMA 2400, AAMA Installation Masters™ ASTM E 2112, FMA/AAMA/WDMA 300-12).**

Failure to follow these recommendations, local requirements, and good building practices may result in poor performance including, but not limited to, operation, security and weatherproofing failures and may void coverage under the applicable Milgard express limited warranty. Provide a copy of these recommendations and the applicable Milgard express limited warranty to the owner before installing. Milgard does not permit adoption of its installation recommendations into the contracts of others without its prior, written consent.

Please contact Milgard at 1-800-645-4273 for clarification.

---





# Assembly and Installation

## Guide for AX550 Bi-fold Doors

---

### Safety and Handling

Installation of the Product is not a “do-it-yourself” project. The Product should be installed only by experienced, qualified and, where required, licensed installation professionals.

- Read and fully understand ALL manufacturer’s instructions prior to beginning the installation. Failure to follow proper installation instructions may affect coverage under the applicable Milgard express limited warranty.
- This is a finished product that must be protected before, during and after installation to prevent damage to the glass, frame, finish and hardware. All component parts, including door panels, should be stored in a dry location that is protected from the elements.
- Before proceeding with installation, inspect the component parts and confirm that there is no damage that will affect appearance or performance. Damaged or missing parts should be reported to your supplier immediately.
- Use caution when working at elevated heights including but not limited to ladders and scaffolding.
- It is the responsibility of the installation contractor to consult and establish appropriate safety and health practices and determine the applicability of regulatory limitations prior to commencing installation.
- Do not work alone and use safe lifting techniques. Two or more people may be required to lift. Use a reasonable amount of people with enough strength to lift, carry and install to avoid injury and/or damage to the Product.
- Use caution when handling glass. Broken or cracked glass can cause serious injury.
- Wear protective gear (safety glasses, gloves, ear protection, etc...).
- Operate hand and power tools safely and follow the manufacturer’s operating instructions.
- Job site and worker protections are recommended and may be required.







# BEFORE YOU INSTALL

## Guide for AX550 Bi-fold Doors

### Read and verify your packaged items.

Prepare the Product for Assembly and Installation **[FIG 01]**

Use the label shown to track door components. Ensure that you have all required components of the Door System and that they are undamaged. Please contact your dealer if you have any questions about your order.

This door is HEAVY, Please use caution during Lifting, Moving, Assembling and Installing this product.

#### STEP 1

Confirm the PO#, MODEL (includes Door Size and style), HANDING match the order that was placed. Handing will be referred to in Panel installation section.

#### STEP 2

Confirm that Door Color matches your order. Hardware box label indicates Hardware color. Check the packing slip on the box to further verify your exact Hardware selections.

#### STEP 3

Check the Package Total indicated below. Ensure you have the full series of packages required to install your door.

*In this example: You would need to receive nine items for installation ranging from Box 1 of 9 to Box 9 of 9.*

**NOTE:** You may access the digital version of this installation guide via the QR code on the label at any time.

**FRAME - HEAD**

**PACKING LIST;**  
FRAME - HEAD

Head wt (Lbs.): ###  
Max Package wt (Lbs.): ###

**STEP 2**

Door Color : BRONZE

Blid : Milgard build number

**CAUTION! HEAVY!**  
**TEAM LIFT REQUIRED**

SO Ln : sales order number here

**STEP 1**

PO : #####  
 Model : 238 3/8 x 96 Bi-fold  
 Handing : 1L3R

BLD Route Code: PO-D-815A
SALE Route Code: CBA

BLD Ship Date: 06/07/20
SALE Ship Date: 06/10/20

CUSTOMER : "YOUR NAME"

Milgard.com/AX550/Install

**BOX 1 OF 9**

**STEP 3**

**FIG 01**



### Requirements for a successfully install :

#### Rough Opening

- o Ensure that the sill is flat and level [FIG 02]
- o Ensure that the entire opening is square and plumb [FIG 03]
- o **The rough opening Header should be designed to carry up to 100 lbs./ Ft for each foot of door width.** Consult with architect or design engineer for specific header requirements.

Example: The Header for a 12-foot-wide door would need to be designed to carry an additional 1200 lbs. of Load from the door itself.

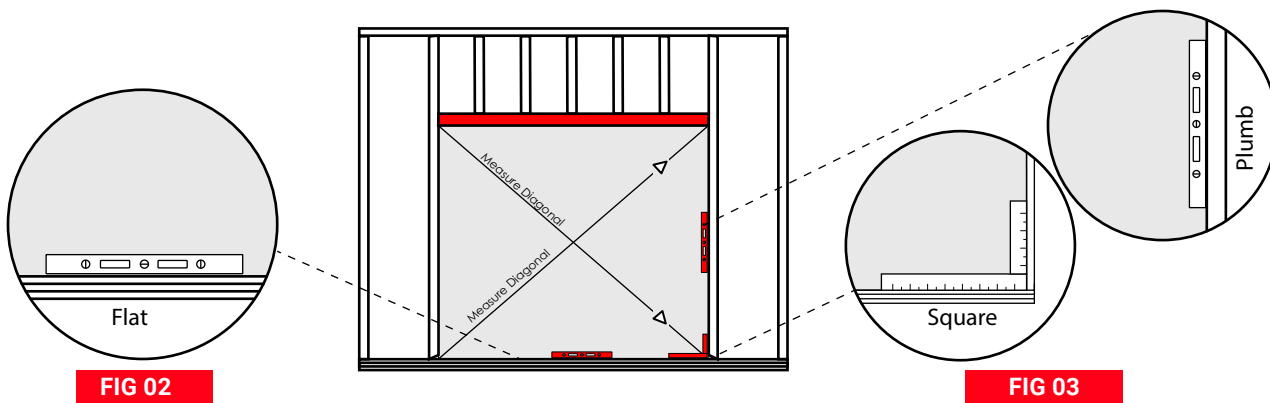

#### Manpower

- o A minimum of two people must be used to install these systems. Three or more is preferred and larger systems may require more than three.

#### Protection from Wind and Rain

- o Systems should be installed with overhead protection from wind and rain to prevent potential damage from water. We recommend that a professional waterproofing consultant be used to ensure proper steps are taken to reduce the potential for damage.

#### Installing in Existing Structures

- o System installation may disturb surfaces and paint in existing structures. Specific notice and work site precautions may be required. Additional information is available at [www.epa.gov/lead](http://www.epa.gov/lead). Comply with all applicable federal, state and local requirements.
- o Special disposal considerations may be necessary for materials used during installation. Materials removed from an existing structure may also have their own disposal or recycling requirements. Comply with all applicable federal, state and local requirements.

#### Warranty Registration

Milgard is dedicated to quality and build our windows and patio doors to last. With the Milgard AX550 Moving Glass Wall, the original homeowner is covered pursuant to the applicable Lifetime Limited Warranty. Register your warranty at [milgard.com/register](http://milgard.com/register)





# BEFORE YOU INSTALL

## Guide for AX550 Bi-fold Doors

### Material and Tool List :

Materials and tools indicated here are general suggestions. Additional or different items may be required dependent on the type of install.

#### Materials Required:

- Non-compressible shims.
- Fasteners for Wood Frame Installation provided
  - o Type and number as required by code.
  - o At minimum fastener type should be sufficient to properly affix the frame and penetrate opening.
- Flexible membrane for sill pan flashing system.
- High quality compatible exterior grade sealant.
- Seal tape for the weather resistive barrier.
- Self-adhering flashing
  - o In a width required by code but no less than 4 inches.
  - o AAMA 711 compliant flexible butyl tape flashing or equivalent is recommended.
- Backer rod.
- 2" Chip brush for spreading Liquid Applied Flashing.
- Joint knife, trowel, or spatula for applying Liquid Applied Flashing.
- Low-expansive, low-pressure foam or batt type insulation.
- DRILL BIT size required: 9/64", 11/64", 15/64" and 3/4".
- ALLEN WRENCH size required: 1/16" and 5/16".

#### Tool Checklist:

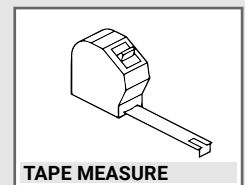
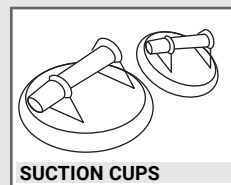
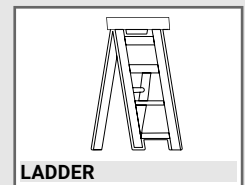
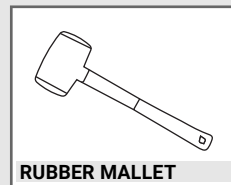
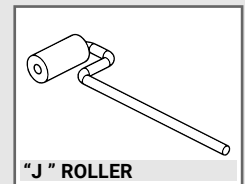
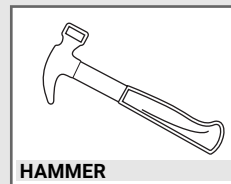
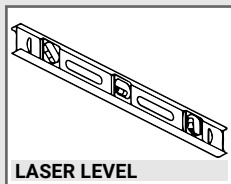



# TABLE OF CONTENTS

Guide for AX550 Bi-fold Doors

## TABLE OF CONTENTS:

<b><u>STEP 1</u></b>	Parts Identification ..... Page 06-12 <i>Not all parts identified are included in ALL Door Systems</i>
<b><u>STEP 2</u></b>	Installation Preparation ..... Page 13-14
<b><u>STEP 3</u></b>	Frame Assembly ..... Page 15-17
<b><u>STEP 4</u></b>	Frame Installation ..... Page 18-20
<b><u>STEP 5</u></b>	Panel Installation ..... Page 21-39
<b><u>STEP 6</u></b>	Accessory Installation ..... Page 40-43

**Note:** Unless specifically indicated on the Figure as “**Interior View**”, All Figures in this installation guide are detailed from door **Exterior**.



# STEP 1- PARTS IDENTIFICATION

## FRAME COMPONENTS

### Shipped in Frame Packaging

#### Frame Sill [FIG 04]

Low Sill or Tall Sill Option

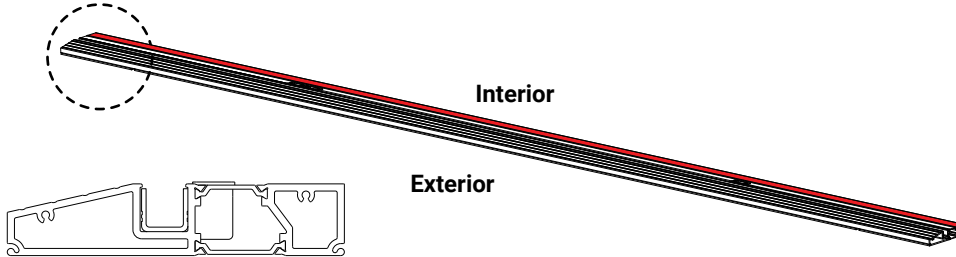

Tall Sill Shown

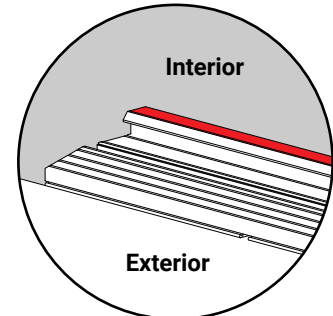

FIG 04

#### Frame Head [FIG 05]

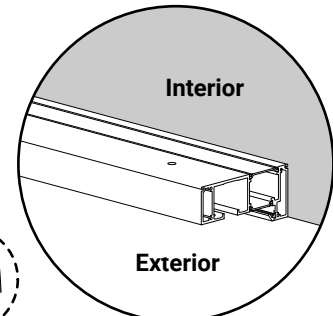
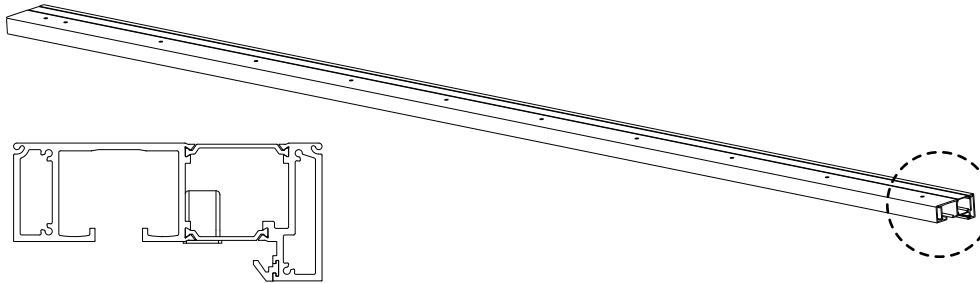

FIG 05

#### Pivot Jamb [FIG 06]

1 or 2 included based on the door configuration.

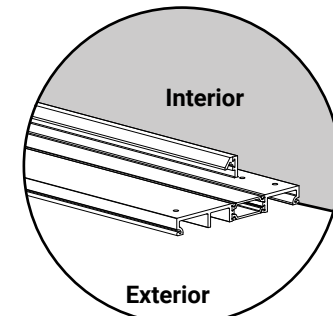
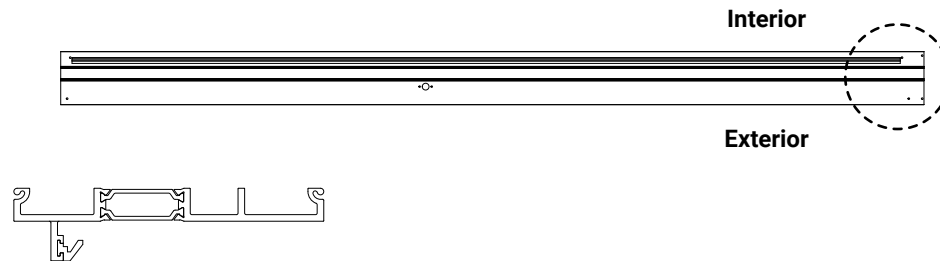

FIG 06

#### Lock Jamb [FIG 07]

0 or 1 included based on the door configuration.

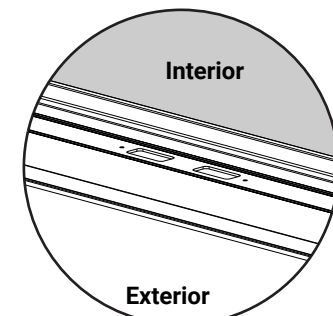
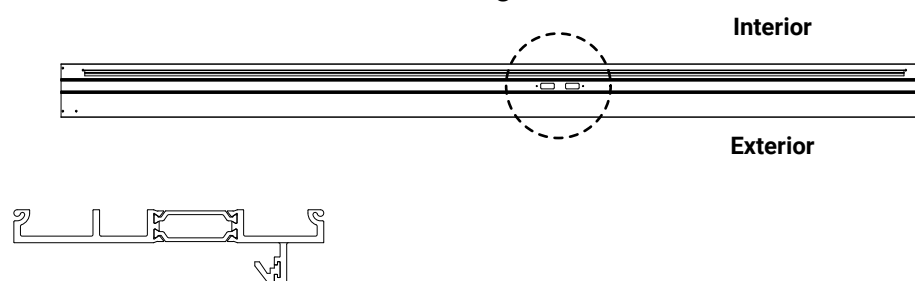

FIG 07



# STEP 1- PARTS IDENTIFICATION

## ACCESSORY BOX COMPONENTS

### Flashing Fin [FIG 08] (Optional)

EX8620 - 1 - <sup>3</sup>/<sub>8</sub> " FIN  
EX8621 - 1" FIN

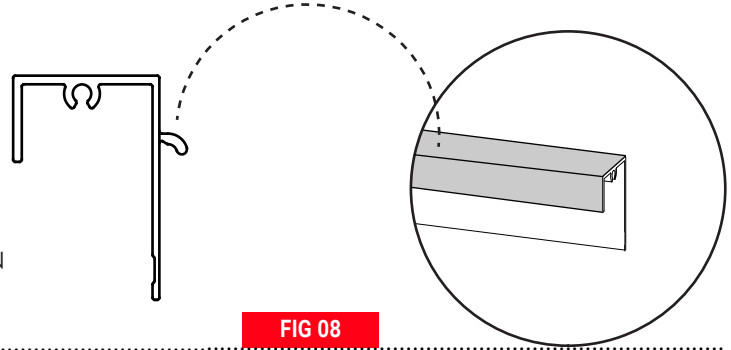

FIG 08

### Sill Ramp [FIG 09] (Optional)

EX8622

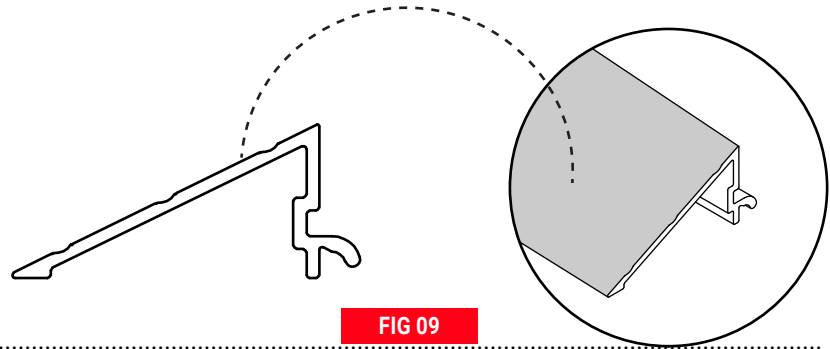

FIG 09



# STEP 1- PARTS IDENTIFICATION

## Hardware Box Comprehensive List

**NOTE: INSTALLER MUST CHANGE HANDING (LEFT/RIGHT ) AS NEEDED.**

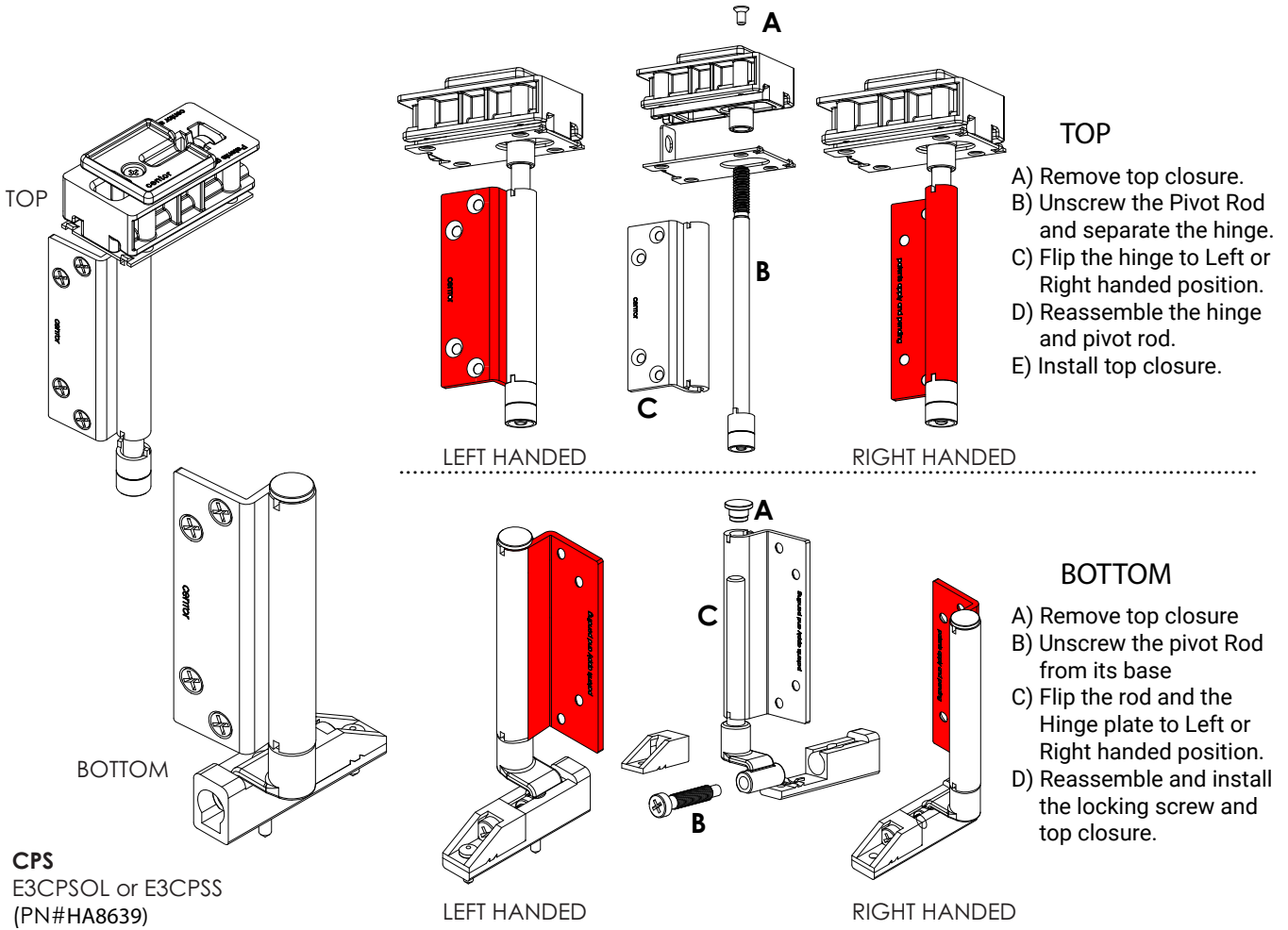

**FIG 10 - PIVOT HINGE SET**

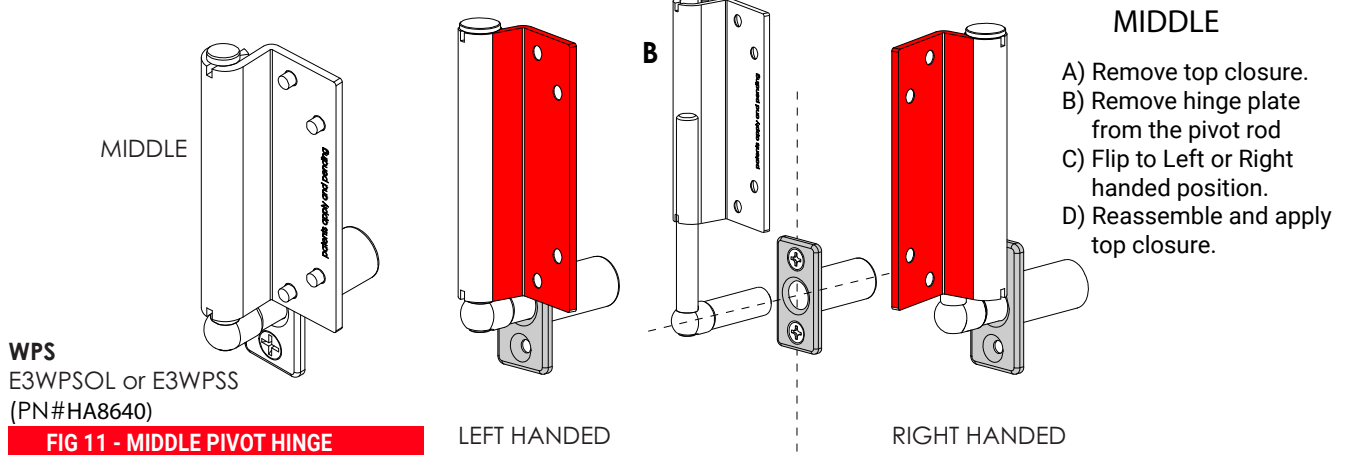

**FIG 11 - MIDDLE PIVOT HINGE**



# STEP 1- PARTS IDENTIFICATION

## Hardware Box Comprehensive List

Not all parts shown below are required for ALL door configurations.

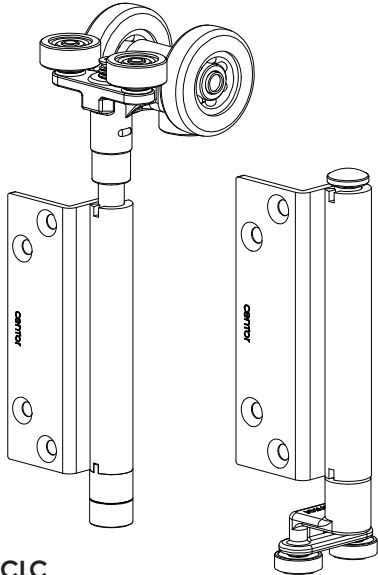

**CLC**  
E3CLCOL or E3CLCSS  
(PN#HA8647)

**FIG 12 - LEFT END CARRIER SET**

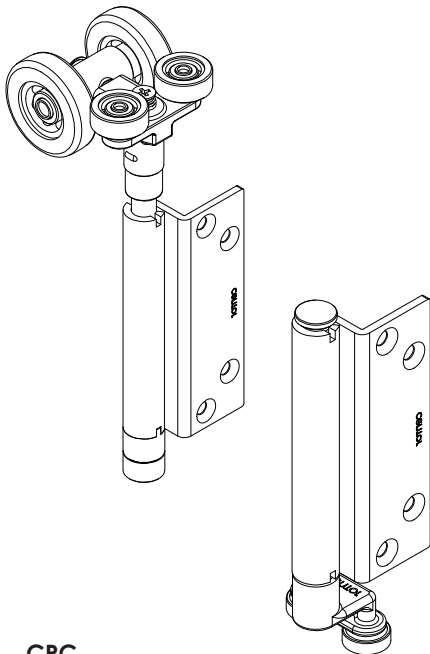

**CRC**  
E3CRCOL or E3CRCSS  
(PN#HA8648)

**FIG 13 - RIGHT END CARRIER SET**

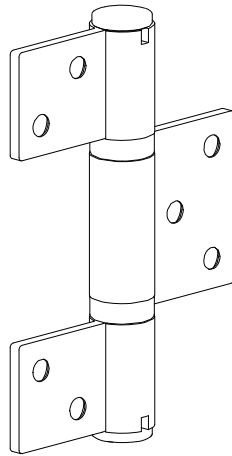

**HNH**  
E3HNHOL or E2HNHSS  
(PN#HA8641)

**FIG 14 - STRAIGHT HINGE (SINGLE)**

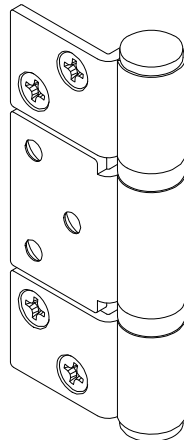

**HHNH**  
E3HHNHOL or E3HHNHSS  
(PN#HA8644)

**FIG 15 - OFFSET HINGE (SINGLE)**

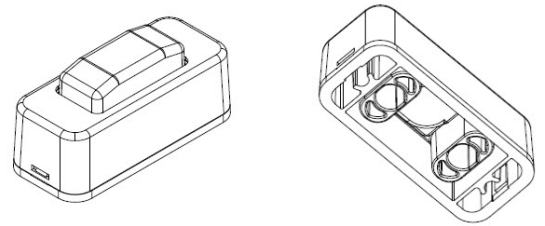

PN#HA8687

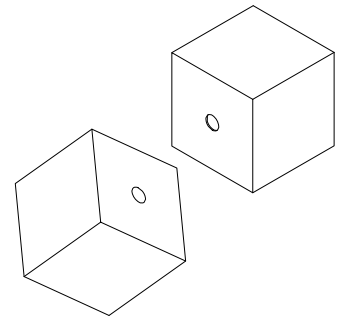

PN#HA8638

**FIG 16 - DOOR HOLDS**

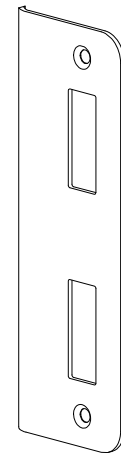

PN#HA8647

**FIG 17 - ASTRAGAL STRIKE**





# STEP 1- PARTS IDENTIFICATION

## Hardware Box Comprehensive List

Not all parts shown below are required for ALL door configurations.

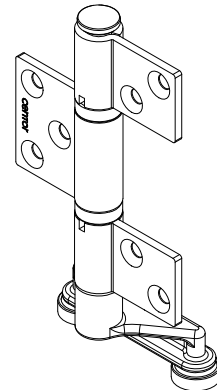
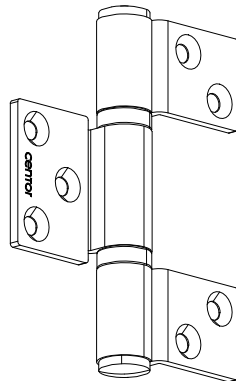
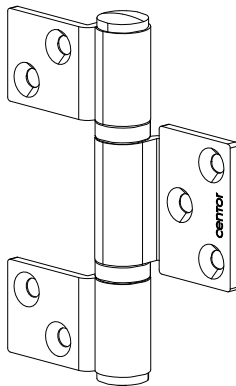
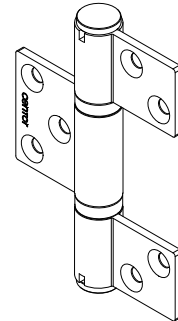
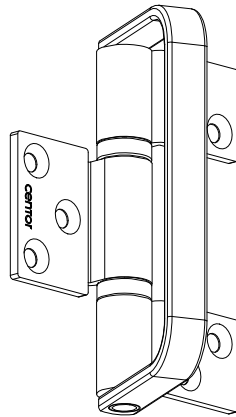
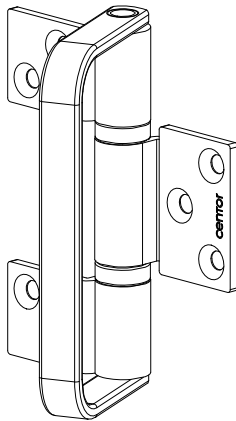
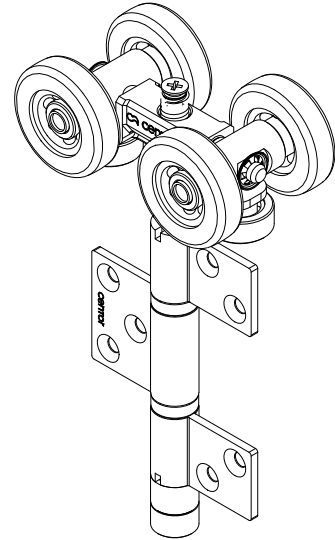
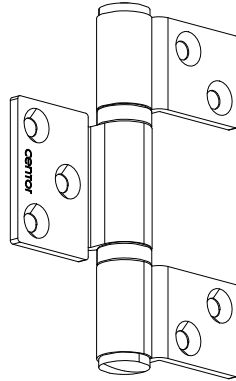
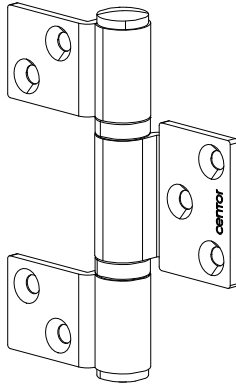

**HHS**  
E3HHSOL or E3HHSS  
(PN#HA8646)

**HS**  
E3HSOL or E3HSS  
(PN#HA8643)

**CICS**  
E3CICOL or E3CICSS  
(PN#HA8649)

**FIG 18 - OFFSET HINGE SET**

**FIG 19 - STRAIGHT HINGE SET**

**FIG 20 - INTERMEDIATE CARRIER SET**



# STEP 1- PARTS IDENTIFICATION

## Hardware Box Comprehensive List

Not all parts shown below are required for ALL door configurations. Extra screws may be provided in your box.

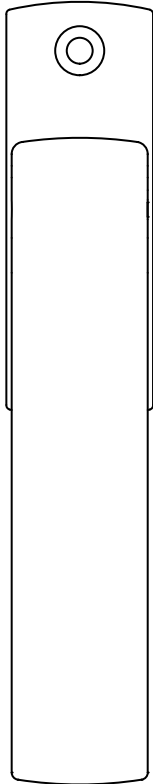

PN#HL8609x

**FIG 21 - SHOOT BOLT HANDLE**

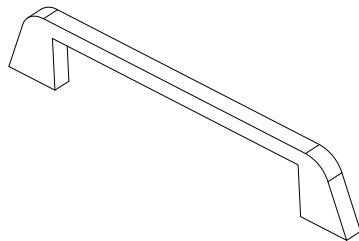

PN#SE8611

**FIG 22 - HINGE GASKET**

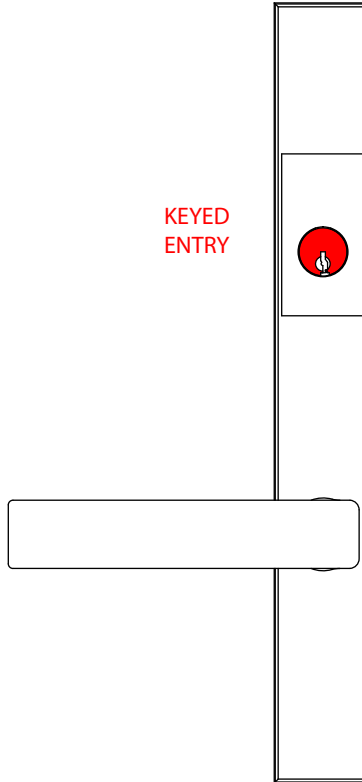

PN#HL8610x |

**FIG 23- ENTRY DOOR HANDLE**

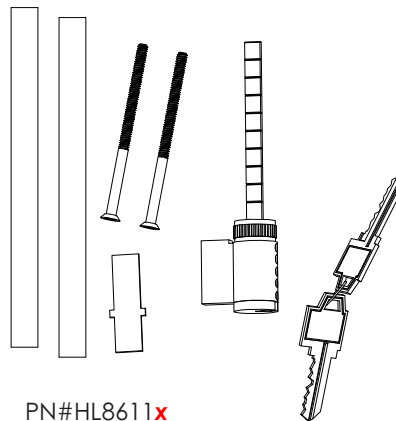

PN#HL8611x

**FIG 24 - ENTRY CONVERSION KIT**

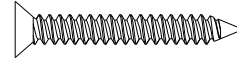

FA0181SS  
#8 X 1-1/2" PHILLIPS PAN HEAD



FA0214SS  
#8 X 2-1/2" SHEET METAL PHILLIPS FLAT HEAD

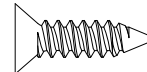

FA0442  
#8 X 5/8" SHEET METAL PHILLIPS FLAT HEAD

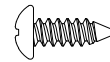

FA0400x  
#8 X 1/2" SHEET METAL PHILLIPS PAN HEAD  
**COLOR MATCHED HEAD x - SS, SSBL, SSWH, SSTN**



FA8612  
#7-19 X 1" PHILLIPS PAN HEAD LEADER POINT

**FIG 25 - ASSEMBLY SCREWS**



FA0316SS  
#8 X 1-1/2" PHILLIPS PAN HEAD



FA8609xBG36  
#10-24 X 3/4" F TYPE PHILLIPS FRAMING SCREW  
**COLOR MATCHED HEAD x - SS, SSBL**

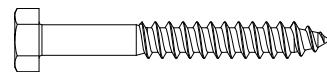

FA8600GA  
#3/8 3" LAG BOLT GALVANIZED



FA8611GA  
#3/8" FLAT WASHER GALVANIZED

**FIG 26 - INSTALLATION SCREWS**



# STEP 2- INSTALLATION PREPARATION

## Rough Opening Inspection

### Inspect and Prepare the Rough Opening

- Ensure the rough opening is in good condition and sits plumb, level and square.
- Confirm overall width, height and diagonal measurements of rough opening
  - Diagonal measurements should be within 1/8" for openings less than or equal to 20 square feet and 1/4" for openings greater than 20 square feet.
- Framing conditions at the rough opening must be sufficient to support the door unit, framing header above, and permit appropriate integration of the door into the building's water management system. Consider if the roof has been loaded or not. The maximum deflection over the entire length should not exceed 1/8", including when the roof is loaded.
- If the building already has a weather resistant barrier (WRB) installed, it is necessary to integrate the door system into the existing WRB. Milgard recommends that the installer follow the WRB manufacturer's recommendation to prepare this opening. The installer must confirm rough opening preparation will not impact the WRB manufacturer's warranty or otherwise inhibit drainage before proceeding.
- Milgard requires the use of a sill pan to allow for any water to drain to the exterior drainage plane. Sill Pan can be rigid or flexible and is mandatory. Sill Pans to be supplied by others and is not included with the Door System. (See next page for details of a L-metal sill pan method using Liquid applied flashing).
- Multi-slide sills come in a variety of riser heights and should be noted as to the one specified for your application. **[FIG 27]**

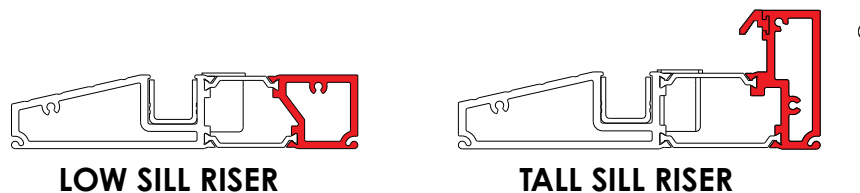

**FIG 27**

- The height of the finish floor must be determined prior to installation and noted somewhere near the opening.



## STEP 2- INSTALLATION PREPARATION

### L - Metal Installation

#### Install 3/4" x 3/4" L - metal aluminum

- Install 3/4" x 3/4" aluminum L-metal the full length of the sill as the raised leg of the liquid applied flashing pan. **[FIG 28]**
- Leave a minimum 1/8" between the door frame and the L-metal. This space will be filled with backer rod and sealant while installing the air & water seal later in this instruction.

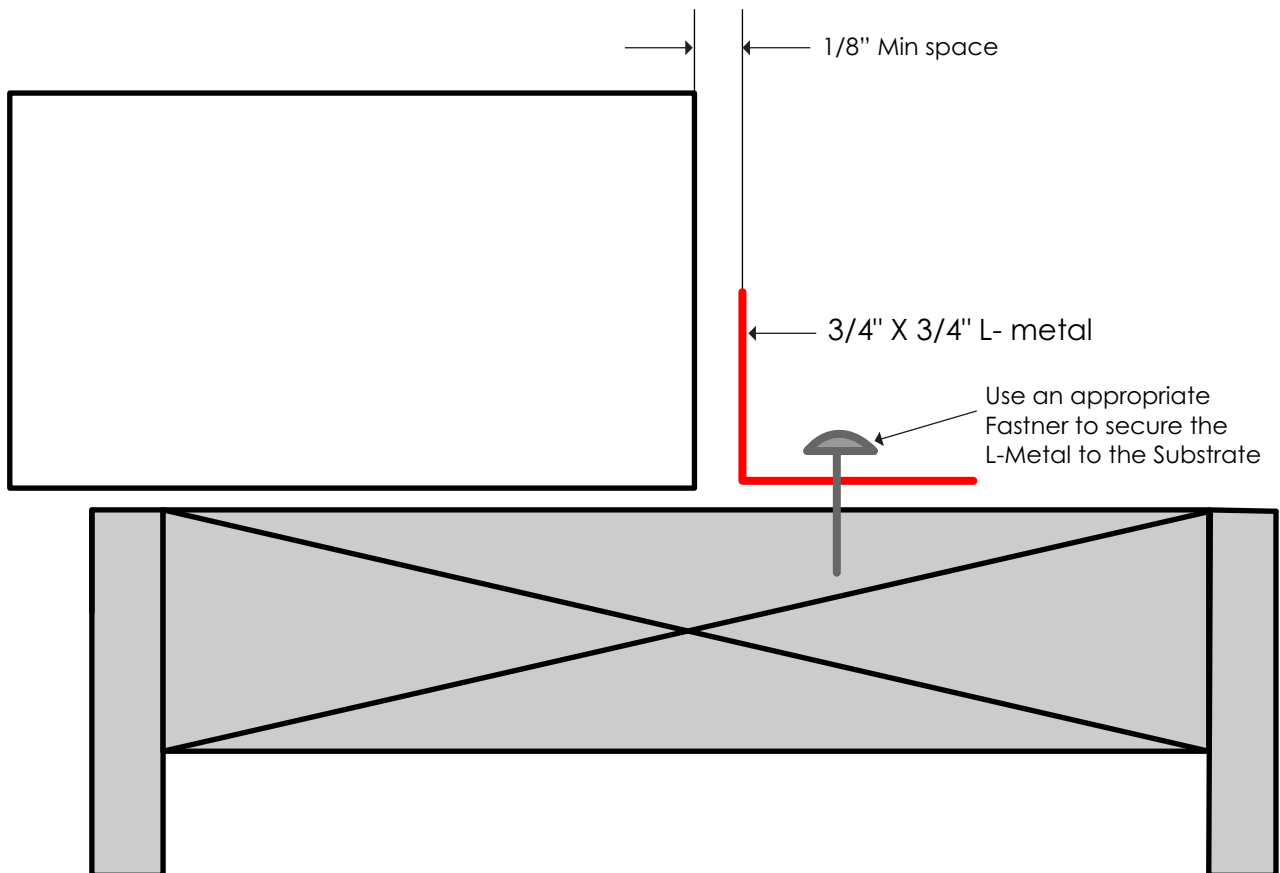

FIG 28



# STEP 3- FRAME ASSEMBLY

## Gather Frame Components

### Prepare parts for Assembly

- Gather frame components in an area with enough flat space to assemble the frame.
- **Tip:** Working near the rough opening will minimize the distance assembled frame needs to be moved after assembly and helps to minimize the damage risk to the assembled frame.
- Remove packaging from frame components.
- Identify frame component's features. **[FIG 29]** (Refer **Step 1 : Parts List** for additional detail).

### Orient and layout the frame pieces for assembly

- o Set the Jamb and Head, with the exterior face down at the head ends of the Jamb.
- o Set the Sill with the exterior face down at the Sill ends of the Jamb.

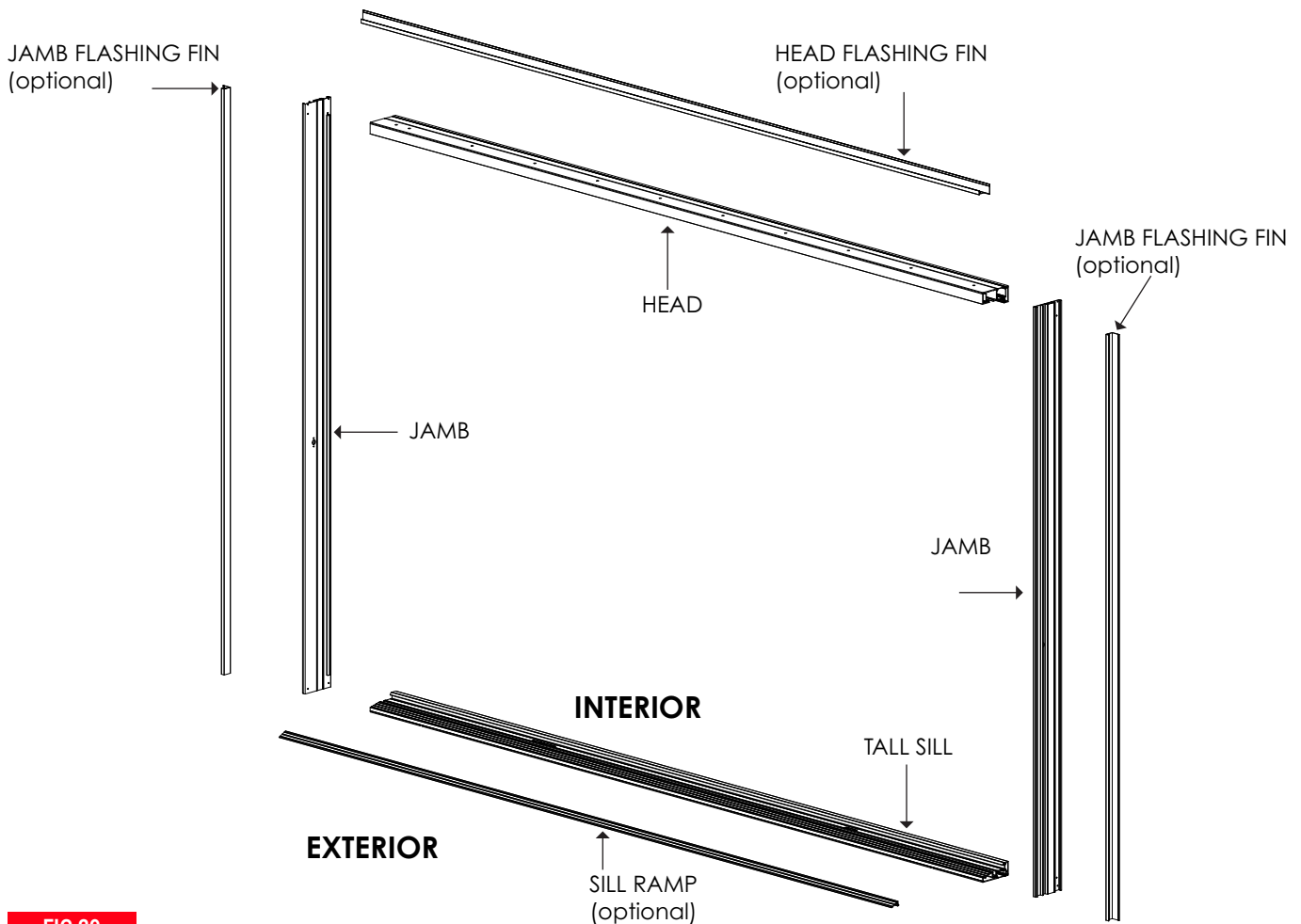

FIG 29



# STEP 3- FRAME ASSEMBLY

## Door System - Optional Features

### Flashing Fin (optional) [FIG 30]

- STEP 1** Dry fit each of the 3 pieces of the Flashing Fin into position by rolling the Flashing Fin's mating feature into the frame's mating slot. Verify cut length, fit and then remove.
- STEP 2** Apply Sealant to the Jamb Flashing Fins, then align mating feature with frame slot and roll it into position.
- STEP 3** Use a screw from the **FA8612** Package at each end of the head Flashing Fin to attach the Flashing Fins on the side Jamb assemblies.

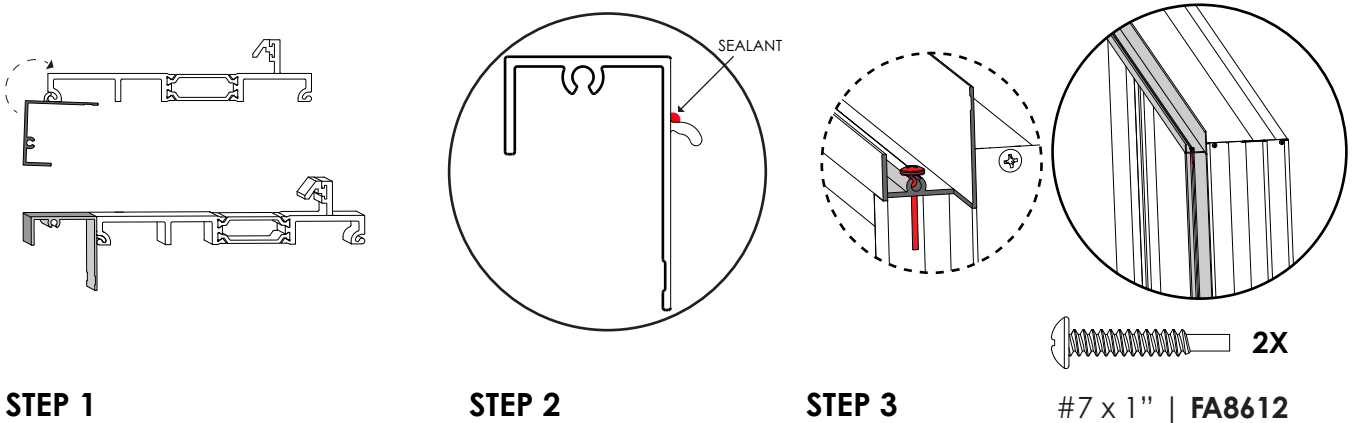

**STEP 1**

**STEP 2**

**STEP 3**

#7 x 1" | **FA8612**

**FIG 30**

### Sill Ramp (optional) [FIG 31]

- STEP 1** Dry fit the Sill Ramp into Sill Assembly by rolling the Sill Ramp's mating feature into the Sill Assembly's mating slot. Verify cut length, fit and then remove.
- STEP 2** Apply Sealant to the Sill Ramp, then align mating feature with frame slot and roll it into position.

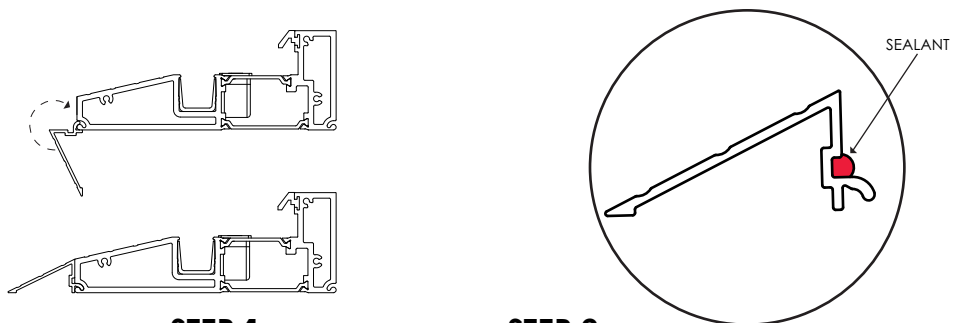

**FIG 31**

**STEP 1**

**STEP 2**



# STEP 3- FRAME ASSEMBLY

## Orient and Assemble Frame

### Frame Assembly (Shown with Optional Features)

- Align the Head end of a Jamb to the Head and screw together from the outside to the inside as shown. Use 4 screws from **FA8612 Package**. **[FIG 32]**
- Align the Sill end of one of the same Jamb to the Sill and screw together from the outside to the inside as shown. Use 3 screws from **FA8612 Package**. **[FIG 33]**
- Repeat steps for the second Jamb.

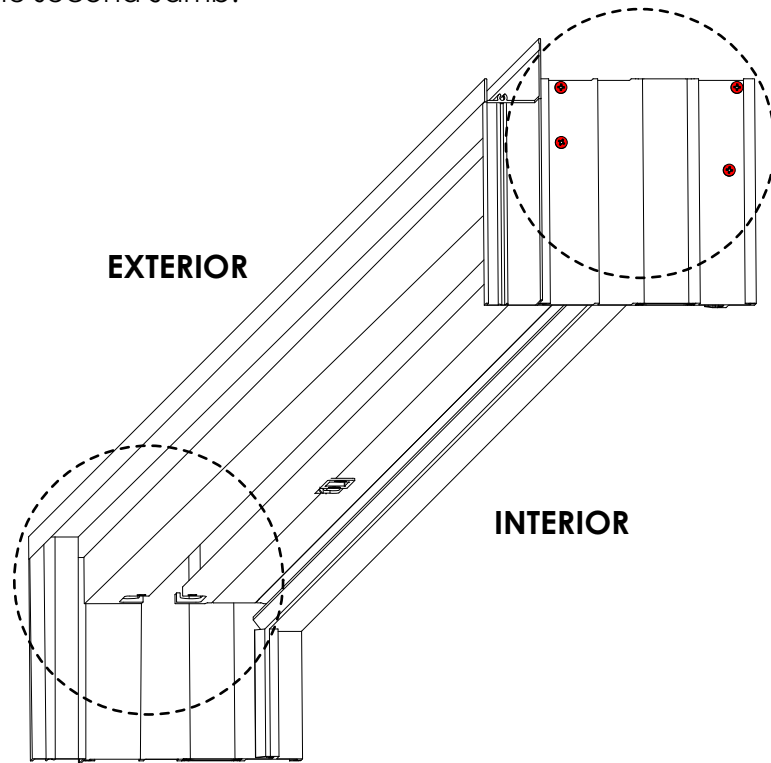
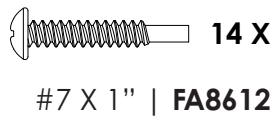

FIG 32

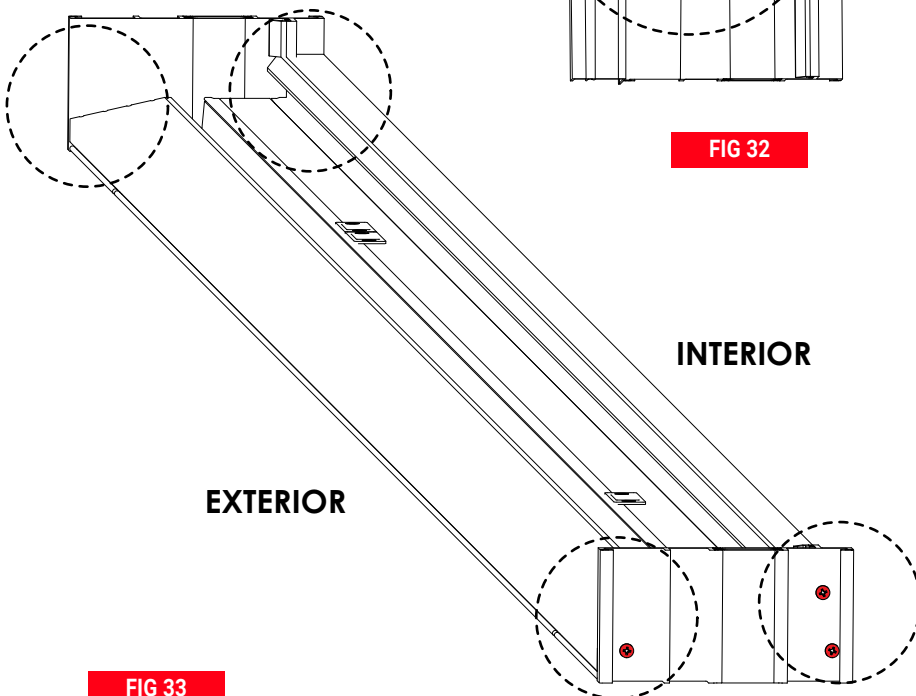
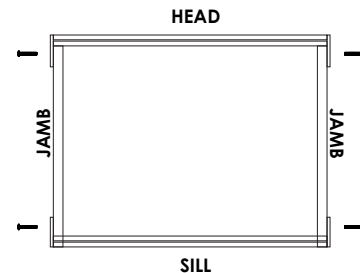

FIG 33



# STEP 4- FRAME INSTALLATION

## Prepare Rough Opening

### Confirm fit of Frame Assembly

- Transport Frame Assembly to Rough Opening.
- Confirm fit of Frame Assembly to the Rough Opening by “Dry fitting” the Frame Assembly into Rough Opening.
  - Make any adjustments required for proper fit, such as the use of shims.
- Remove Frame Assembly from Rough Opening after confirmation of fit and place the exterior face flat on the ground.

### Prepare rough opening: [FIG 34]

- Preparation:

To ensure best results, apply Liquid Applied Flashing to clean surface free of contaminants. Chemical residues, surface oxidation, surface coatings or films may adversely affect adhesion. Pressure-treated or fire-retardant wood and other contaminated surfaces should be cleaned with an Isopropyl Alcohol wipe and allowed to flash-off before application of Liquid Applied Flashing products. Concrete must be in place 3-7 days and free of any curing compounds or form release agents before permeable Liquid Applied Flashing products are applied.
- Liquid flashing application:
  - Apply a bead of Liquid Applied Flashing in each corner of the rough opening and at the sheathing-to stud transition, and fully cover the upturned leg of the L-metal then strike smooth with a DRY tool. Joint widths up to 1/4 inch may be treated with Liquid Applied Flashing and no backer rod. Treat joints ranging from 3/8 inch to 1 inch with backer rod and a Joint & Seam Filler.
  - Apply Liquid Applied Flashing over the exterior inside framing of the rough opening and onto the exterior vertical wall surface 4–6 inches to create a 12–15 mil thick monolithic, pinhole free flashing surface.
  - Allow treated surfaces to skin before installing windows, doors and other wall assembly, components.

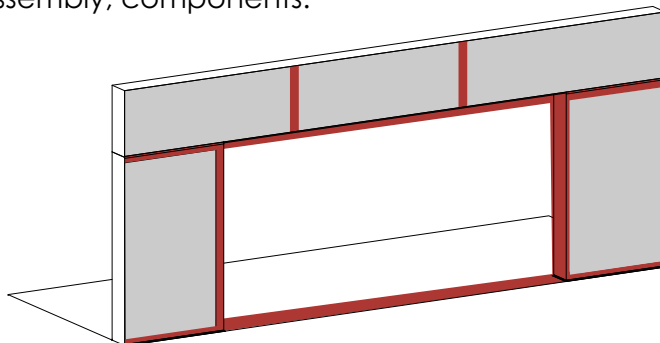

**EXTERIOR VIEW**

**FIG 34**







## STEP 4- FRAME INSTALLATION

### Sealing Exterior Flashing Flange

Seal the exterior Door Flange: [FIG 35]

- Install the door “plumb, level and square” into the rough opening prepared with a Joint & Seam Filler and Liquid Applied Flashing.
- To “wet-set” the exterior door flange, install a continuous bead of Sealant on the back of the flange along the top (head) and sides (jamb) of the door.  
**Note:** Make sure to leave the sill flange free of Sealant for drainage capabilities.
- Place the door in the prepared rough opening. Install fasteners along the Head, Sill and Jamb using the prefabricated fastner pattern.  
Use FA0371 to install the Head and the Jamb. Use FA0316 to install the Sill.
- Limit counter flashing to the top (head) and sides (jamb) of the door. Do not seal the door bottom (sill) or obstruct weeps.
- Apply a thick bead of Liquid Applied Flashing over the outer edge of the door flange at the door head and jamb. Use a dry joint knife, trowel, or chip per brush to spread the wet product to create a seamless membrane, directing bulk water away from the door and the rough opening.
- Apply additional Liquid Applied Flashing as needed to create an opaque, monolithic membrane free of voids or pinholes.
- Ensure both jamb and the head-to-wall interfaces are covered. Do not seal the door bottom (Sill) or obstruct weeps.

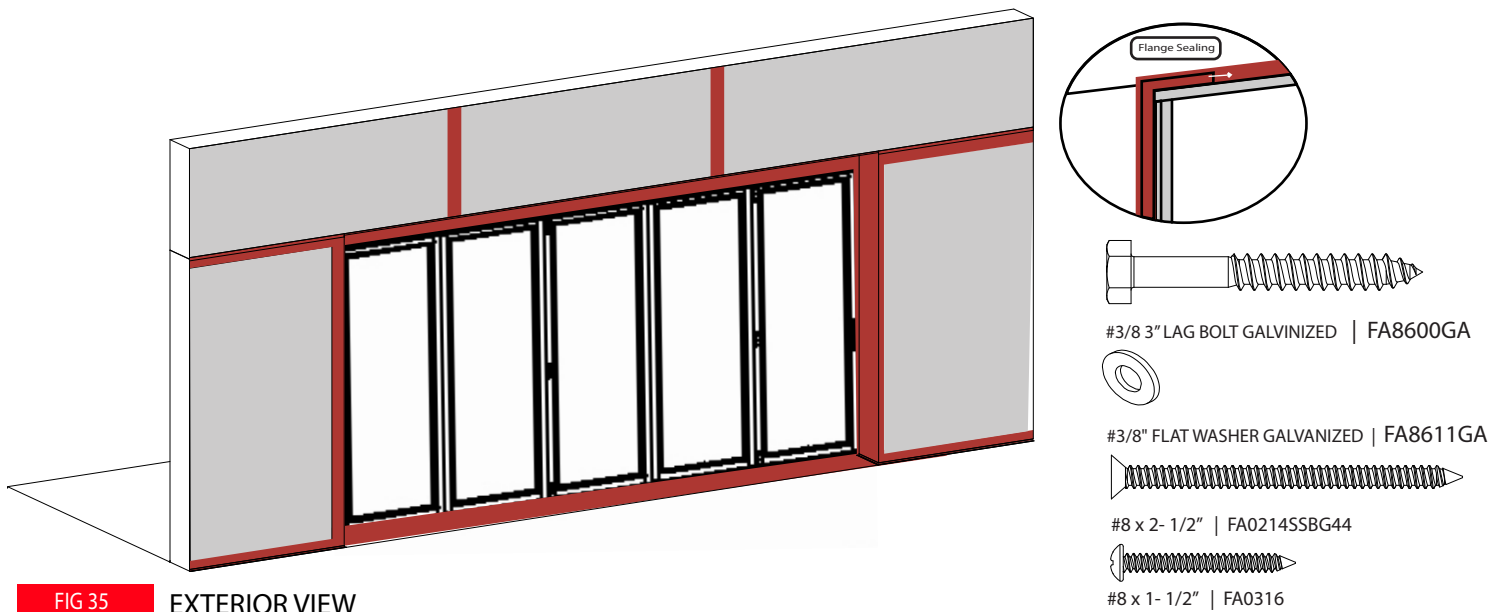

FIG 35 EXTERIOR VIEW



## STEP 4- FRAME INSTALLATION

### Interior Air and Water Seal

#### Install the Interior Air and Water Seal using Backer Rod and Sealant [FIG 36]

- Use Sealant as the interior air dam to ensure compatibility with the treated rough opening and create a long-lasting, weather-tight seal. The Sealant prevents bulk water and moist outside air from entering, and conditioned indoor air from escaping around the door. This ties the door into the larger air and water management system and prevents water which may collect in the door frame from entering the conditioned space.
  - **Joint Size** – Sealant depth should be one-half the width of the joint. Maximum sealant depth should be ½ inch (13 mm). Minimum sealant depth should be ¼ inch (6 mm). Minimum joint width should be ¼ inch (6mm).
  - **Joint Backing** – A properly sized non-gassing polyethylene foam backer rod should compress by 25-30% when installed. Install backer rod by compressing and rolling continuously into the joint channel without stretching or puncturing.
  - **Installation** – Install a continuous bead of Sealant without gaps or air pockets. Tool immediately with a dry spatula to ensure complete wetting of the joint bond surface and produce a smooth, concave joint profile.

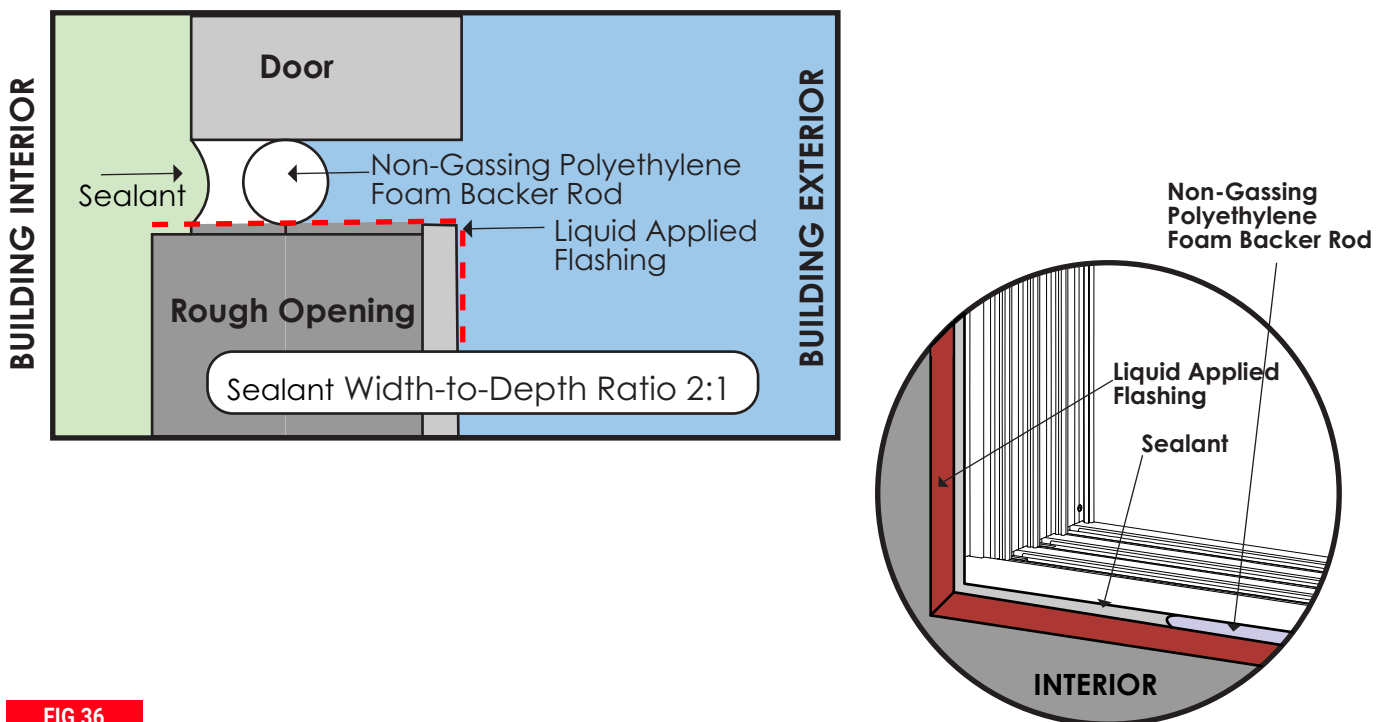

FIG 36





# STEP 5- PANEL INSTALLATION

## Gather Hinge Hardware

### Before you begin panel installation;

Collect hinges from the Hardware box and place in front of the Sill as shown in the example below.

Refer to the UX label on your door for handing. **[FIG 37]** provides an example.

These part numbers are abbreviated below, for simplification

- E3CPSOL or E3CPSS = CPS
- E3WPSOL or E3WPSS = WPS
- E3HHSOL or E3HHSS = HHS
- E3CICOL or E3CICS = CIC
- E3CLCOL or E3CLCS = CLC
- E3CRCOL or E3CRCS = CRC
- E3HSOL or E3HSS = HS

**Note:** OL and S at the end of the part number indicate color only.

HHNH = E3HHNHOL or E3HHNHSS

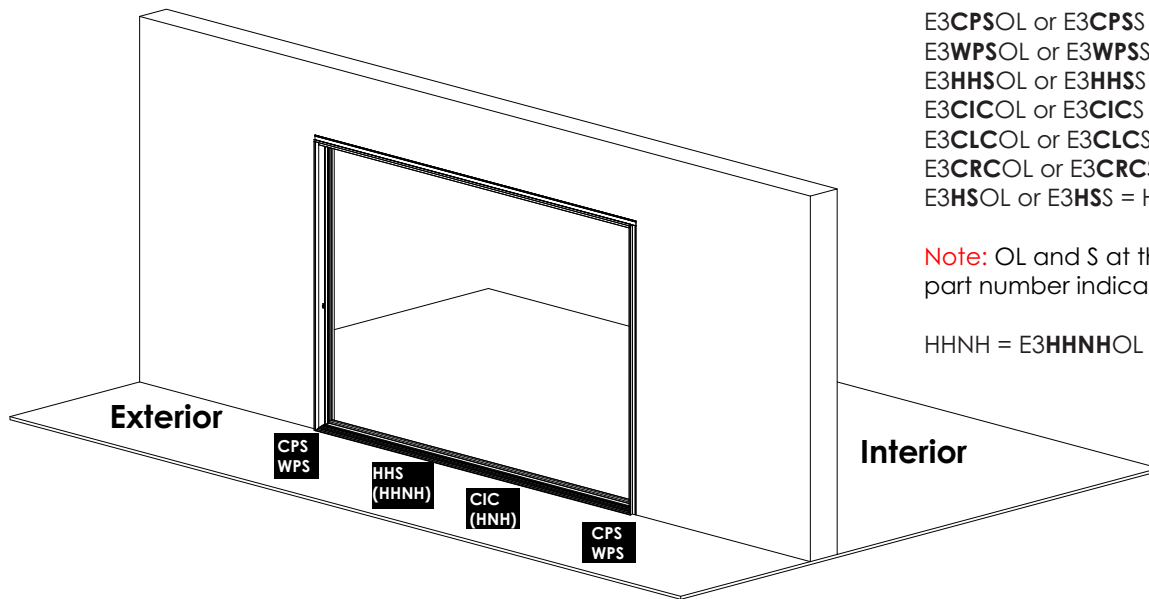

Example; **3L1R**

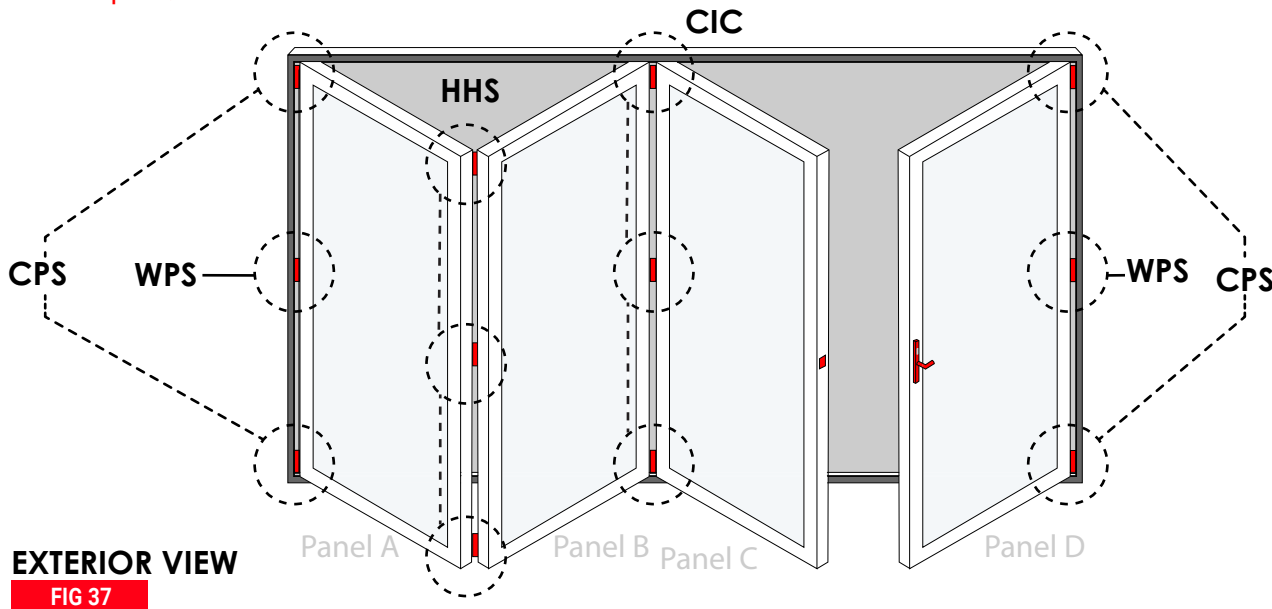

# STEP 5- PANEL INSTALLATION

## Node Positioning

**What is a Node? A Node is a panel connection point.**  
**Diagram below shows Node positions for each Door Handing**

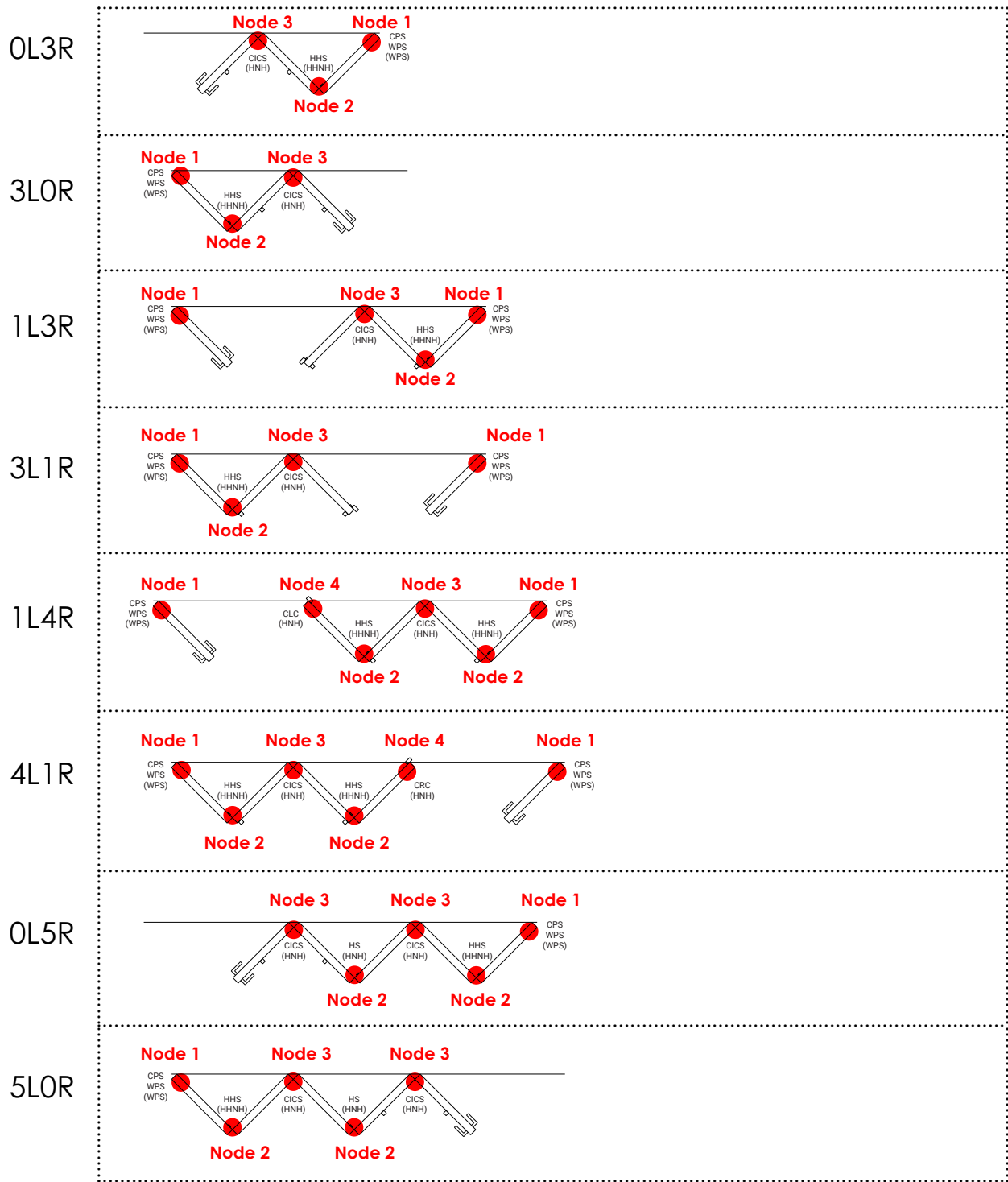

# STEP 5- PANEL INSTALLATION

## Hardware and Nodes for 0L3R or 3L0R

**Note:** Based on your Door System, Hardware Handing may need to be modified. Refer Page 09. Door Frames taller than 8' use additional middle hinges.

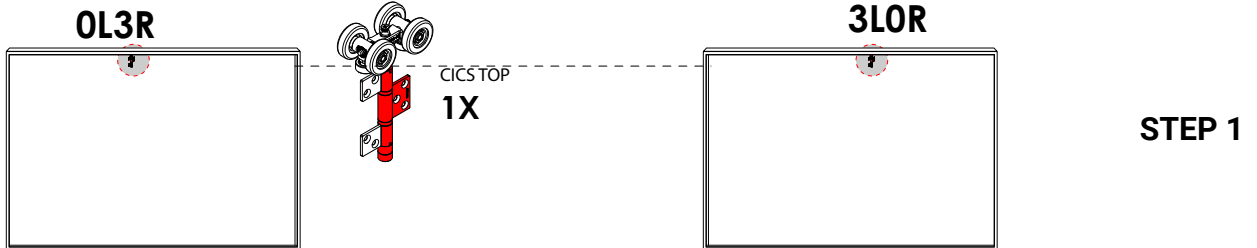

**NOTE:** Insert Intermediate Carrier in HEAD RAIL.  
This Hinge will be attached to **PANEL B** in **STEP 4**.

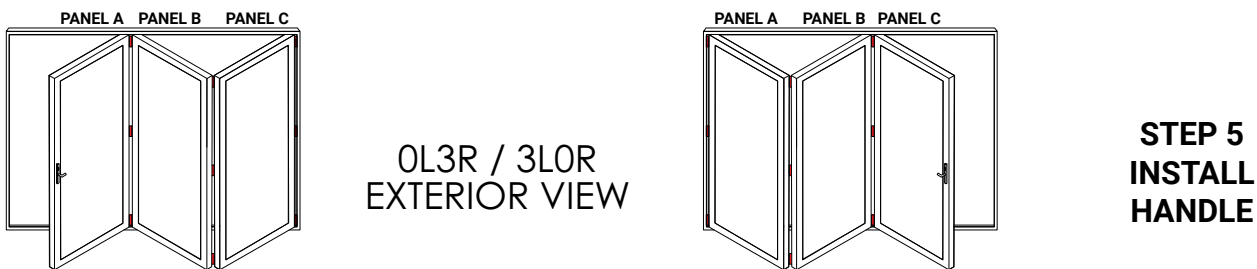
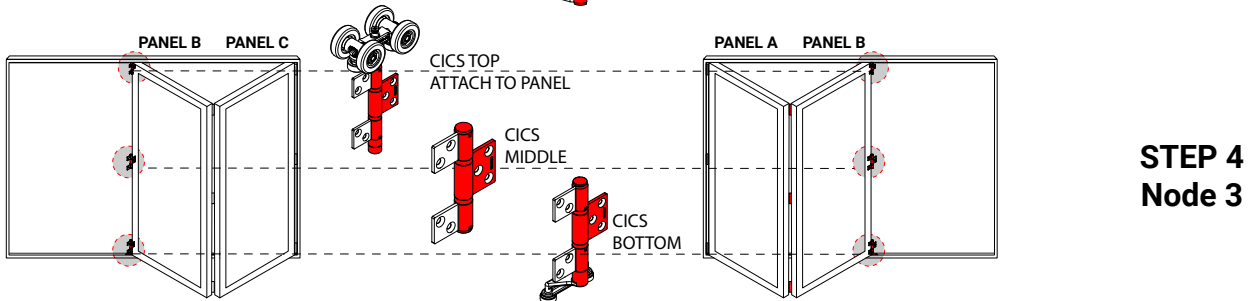
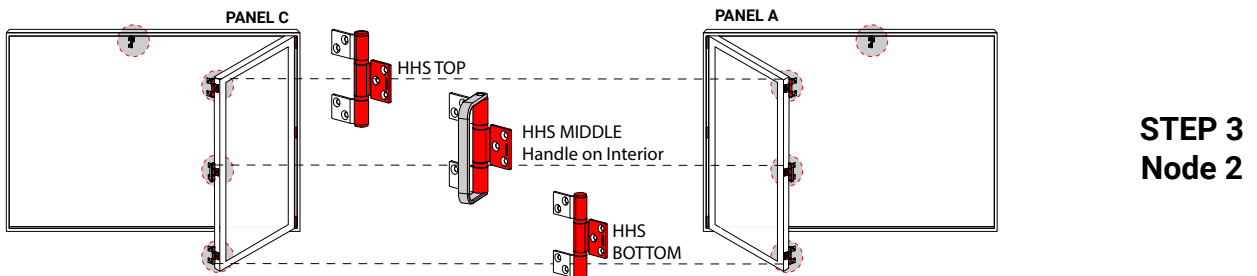
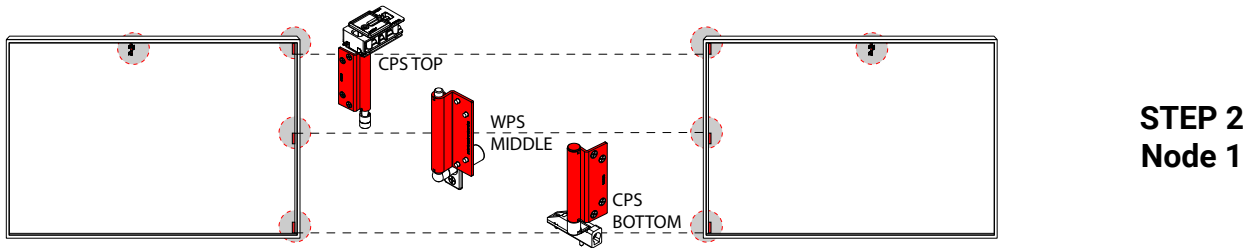

# STEP 5- PANEL INSTALLATION

## Hardware and Nodes for 3L1R or 1L3R

**Note:** Based on your Door System, Hardware Handing may need to be modified. Refer Page 09. Door Frames taller than 8' use additional middle hinges.

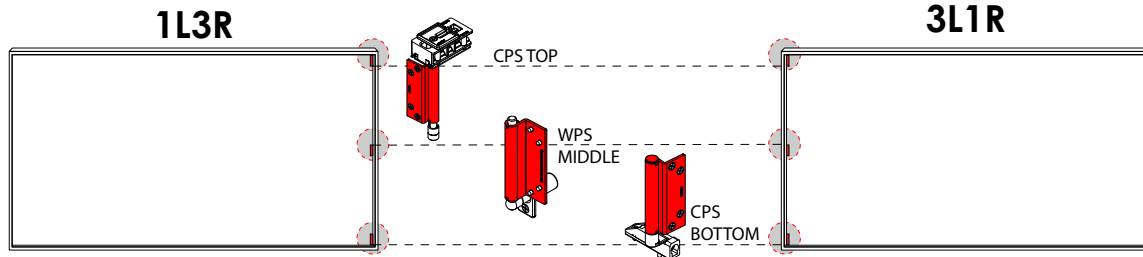

**STEP 1**  
**Node 1**

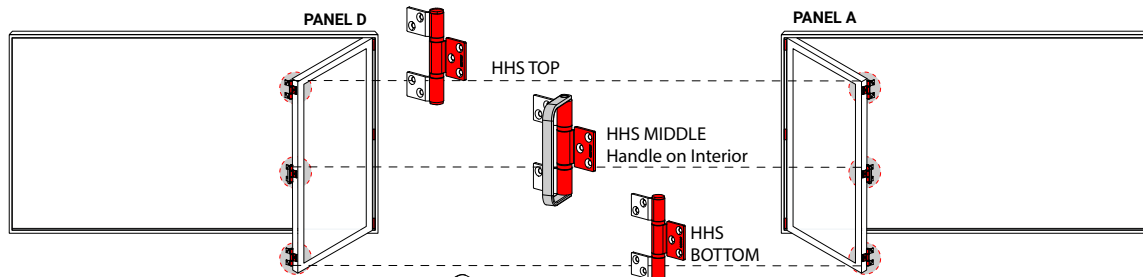

**STEP 2**  
**Node 2**

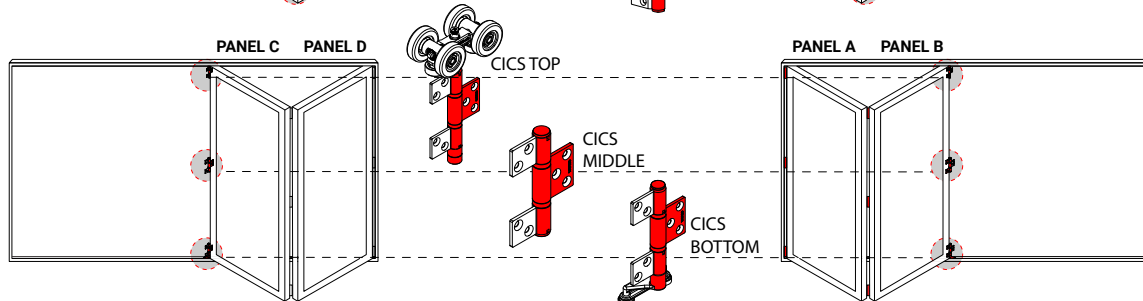

**STEP 3**  
**Node 3**

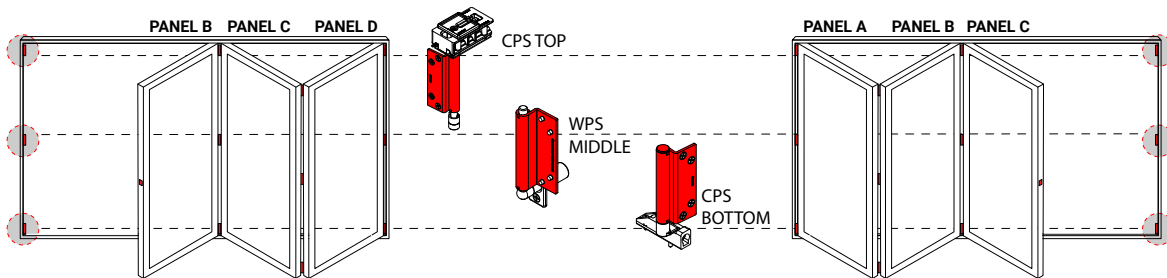

**STEP 4**  
**Node 1**



**STEP 5**  
**INSTALL**  
**HANDLES**





# STEP 5- PANEL INSTALLATION

## Hardware and Nodes for 1L4R or 4L1R

**Note:** Based on your Door System, Hardware Handing may need to be modified. Refer Page 09. Door Frames taller than 8' use additional middle hinges.

**1L4R**

**4L1R**

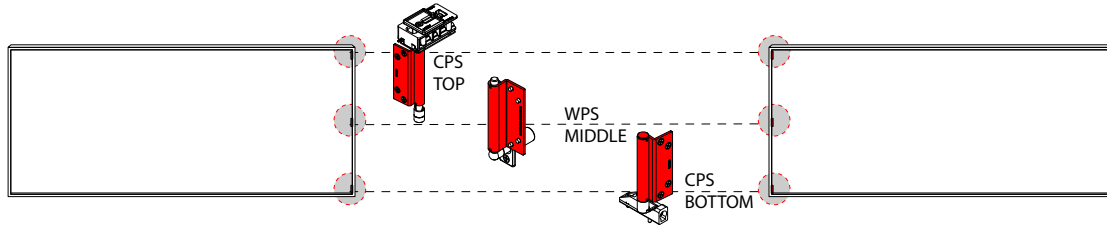

**STEP 1**  
**Node 1**

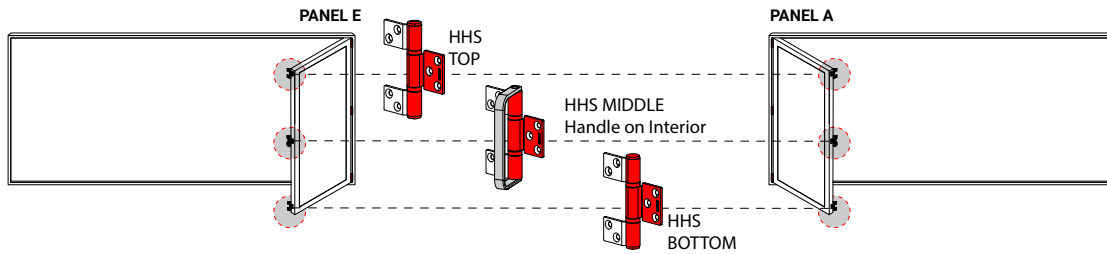

**STEP 2**  
**Node 2**

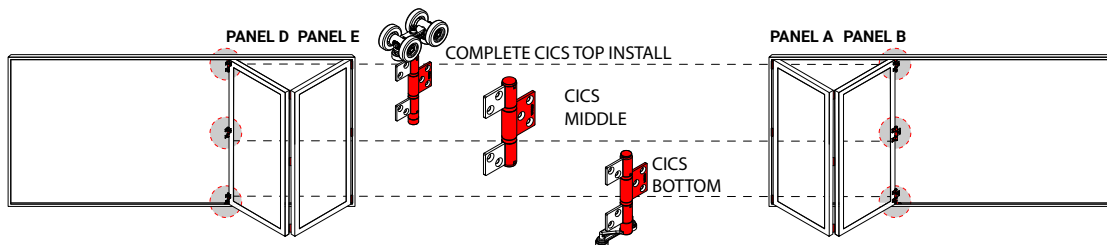

**STEP 3**  
**Node 3**

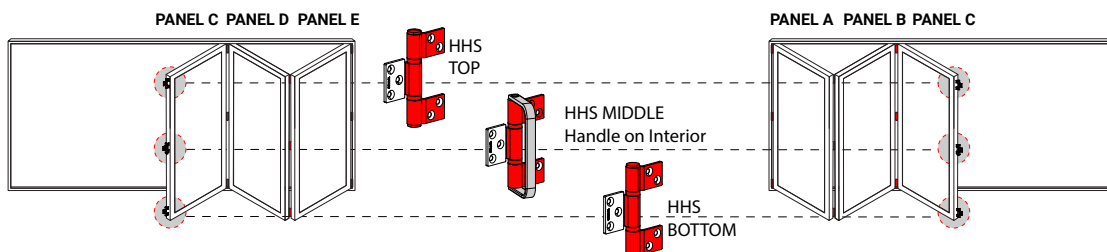

**STEP 4**  
**Node 2**

Continued on next page...





# STEP 5- PANEL INSTALLATION

Hardware and Nodes for 1L4R or 4L1R continued...

**Note:** Based on your Door System, Hardware Handing may need to be modified. Refer Page 09. Door Frames taller than 8' use additional middle hinges.

**1L4R**

**4L1R**

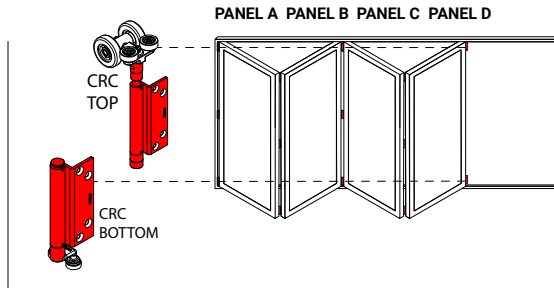
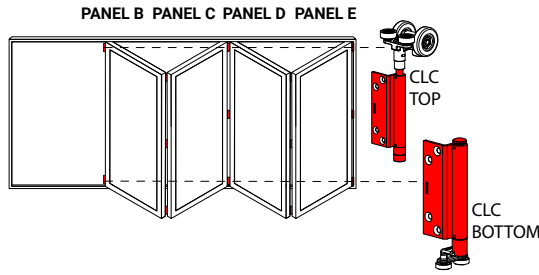

**STEP 5  
Node 4**

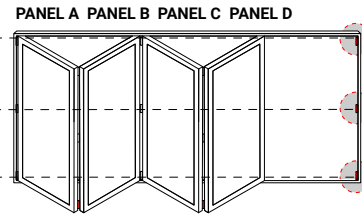
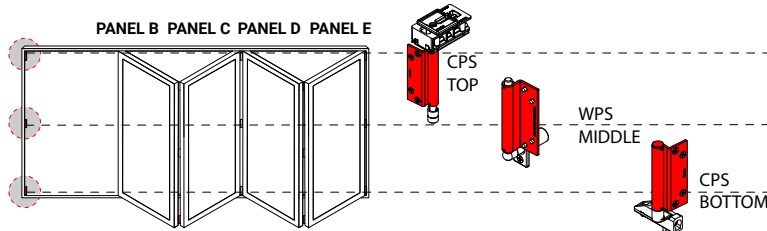

**STEP 6  
Node 1**

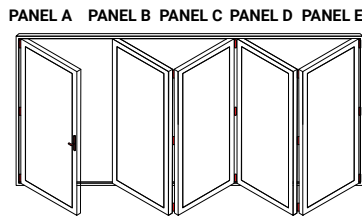

1L4R / 4L1R  
EXTERIOR VIEW

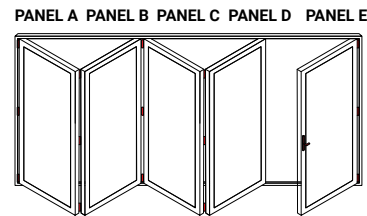

**STEP 7  
INSTALL  
HANDLE**





# STEP 5- PANEL INSTALLATION

## Hardware and Nodes for 0L5R or 5L0R

**Note:** Based on your Door System, Hardware Handling may need to be modified. Refer Page 09. Door Frames taller than 8' use additional middle hinges.

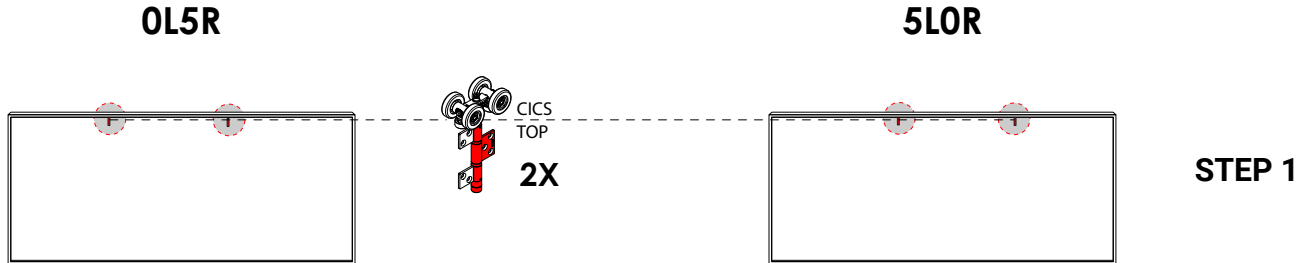

**NOTE:** Insert 2 Intermediate Carrier TOPS in the HEAD RAIL. These Hinges will be attached to panels in STEP 4 and STEP 6.

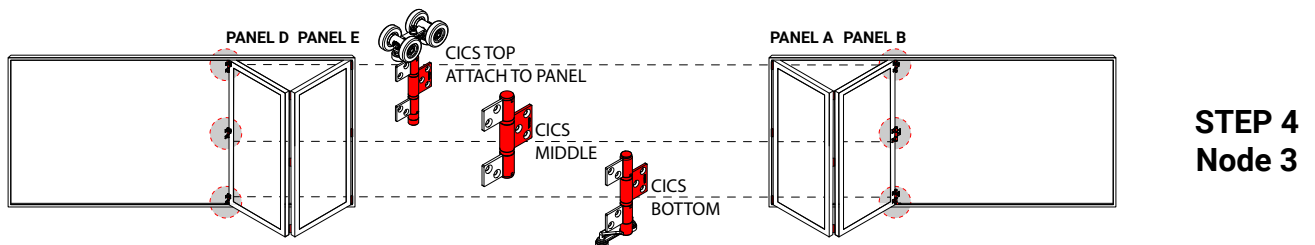
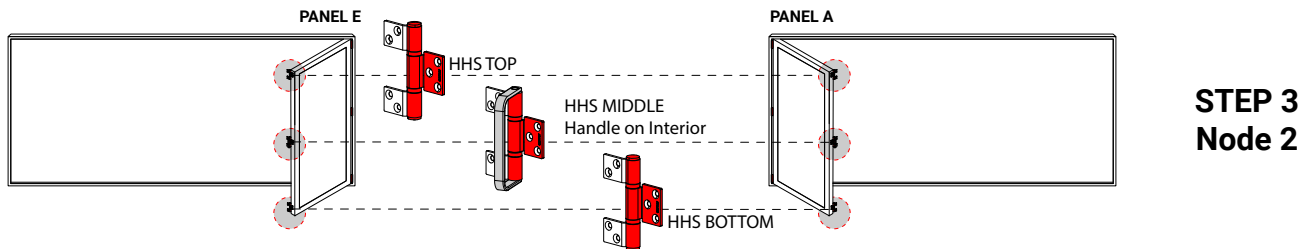
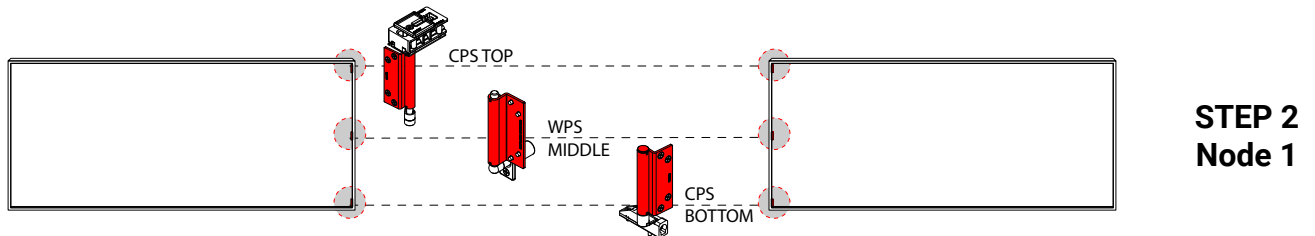

Continued on next page...





# STEP 4- PANEL INSTALLATION

Hardware and Nodes for 0L5R or 5L0R continued...

**Note:** Based on your Door System, Hardware Handling may need to be modified. Refer Page 09. Door Frames taller than 8' use additional middle hinges.

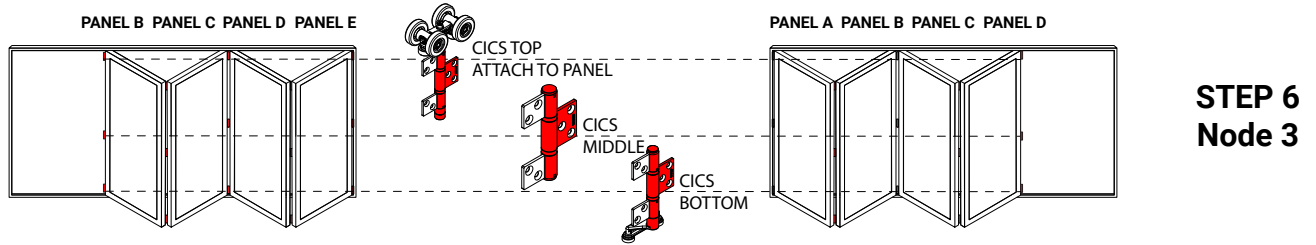
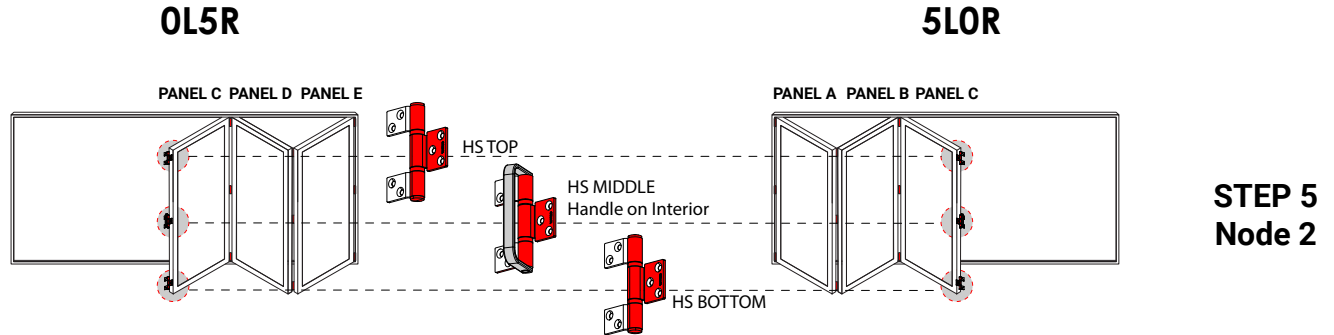

# STEP 5- PANEL INSTALLATION

## Hinge Hardware into Neutral Position

**Prior to installation set Hinges to neutral position; [FIG 38]**

**Set to Neutral Horizontal Position for CPS, CIC, CLC and CRC.**

- A1 Use a Phillips head screw driver to horizontally screw the adjustment screw counterclockwise until it stops rotating freely.
- A2 Next turn 7 rotations clockwise and stop.

**Set to Neutral Vertical Position for CPS, CIC, CLC and CRC.**

- B1 Use an Allen Wrench to turn the screw counterclockwise all the way until it stops rotating freely.
- B2 Now turn 4 rotations clockwise and stop.

### CPS TOP

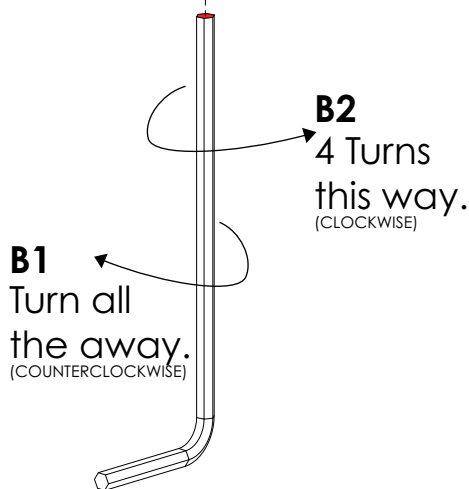
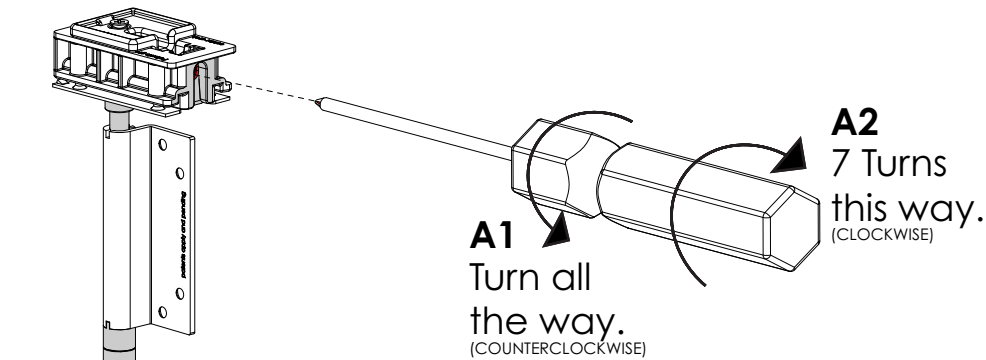

### CPS BOTTOM

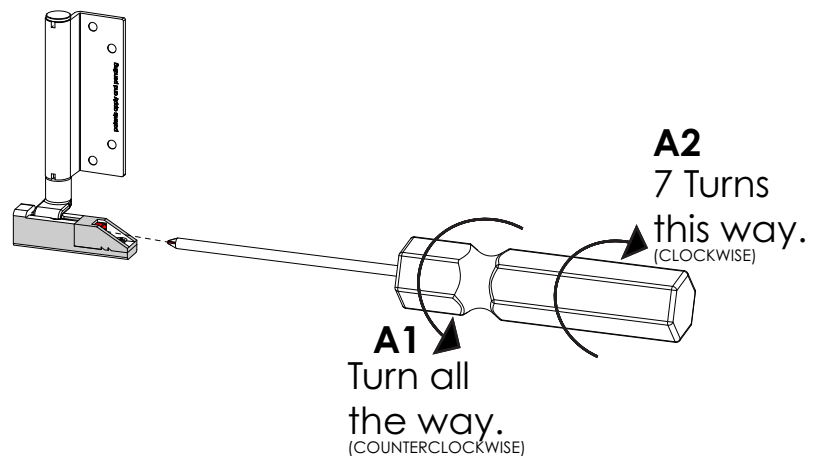

FIG 38



# STEP 5- PANEL INSTALLATION

## PANEL IDENTIFICATION

**SAFETY WARNING: DOOR PANELS ARE HEAVY. BEFORE INSTALLING ENSURE YOU HAVE THE APPROPRIATE NUMBER OF PEOPLE AND TOOLS TO HANDLE AND MANEUVER THE PANELS SAFELY**

- All Panels must be installed into the frame from the exterior. Leave corner packaging on until you are ready to install the specific panel to ensure you can identify the correct panel.
- Each Panel needs to be oriented as shown below before installation **[FIG 39]**
  - Panel Sticker is applied on exterior of the Panel.
  - Panel Sticker is oriented as shown marking the bottom of the Panel
  - Panel Order of installation meets this model.

### Identify Panel Name. **[FIG 40]**

**Note:** Panels are ALWAYS named alphabetically from LEFT to RIGHT as viewed from the exterior.

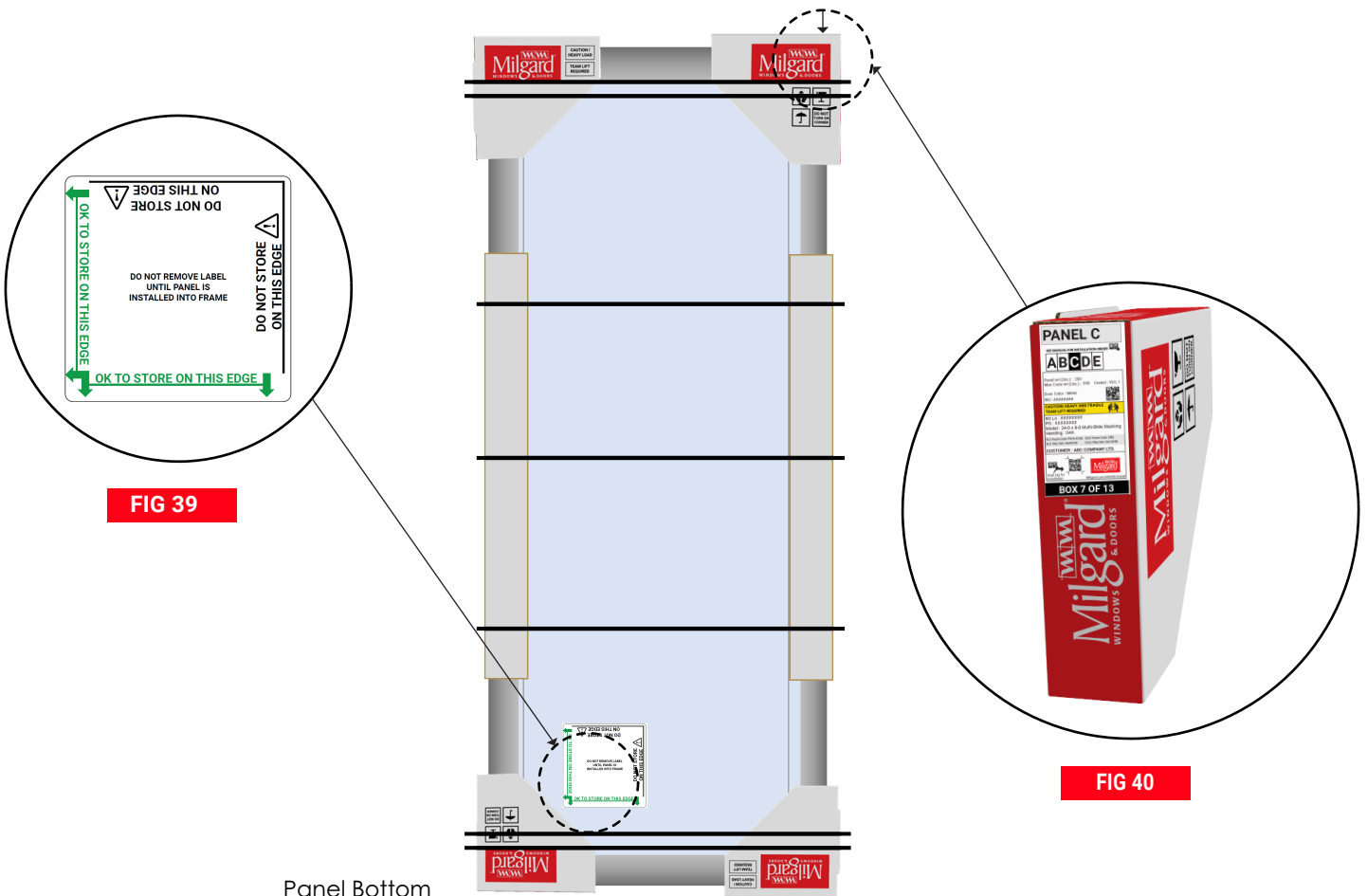

# STEP 5- PANEL INSTALLATION

## Node 1

### Hardware installation at Node 1

Start with the Pivot Jamb on the side where 2 or more panels collect in the open position.

**Important:** Check Hinge and if required change handing position per your model requirement. Instructions on how to change handing is available under Parts List. **[FIG 10]**

### Install CPS Top Hinge in the Head. **[FIG 41]**

- o Check hardware handing position.
  - o Lower the metal plate as much as you can without disassembling it.
  - o Insert the top part of the pivot hinge into the aperture on the header leaving the plate below the header.
- Note:** Some Handings may require moving the CPS carrier through the Head to its correct Nodal position.
- o Attach 4 screws (included in CPS box) into the CPS top unit.  
Do not over-tighten the screws as the hinges will need adjustments in later steps.

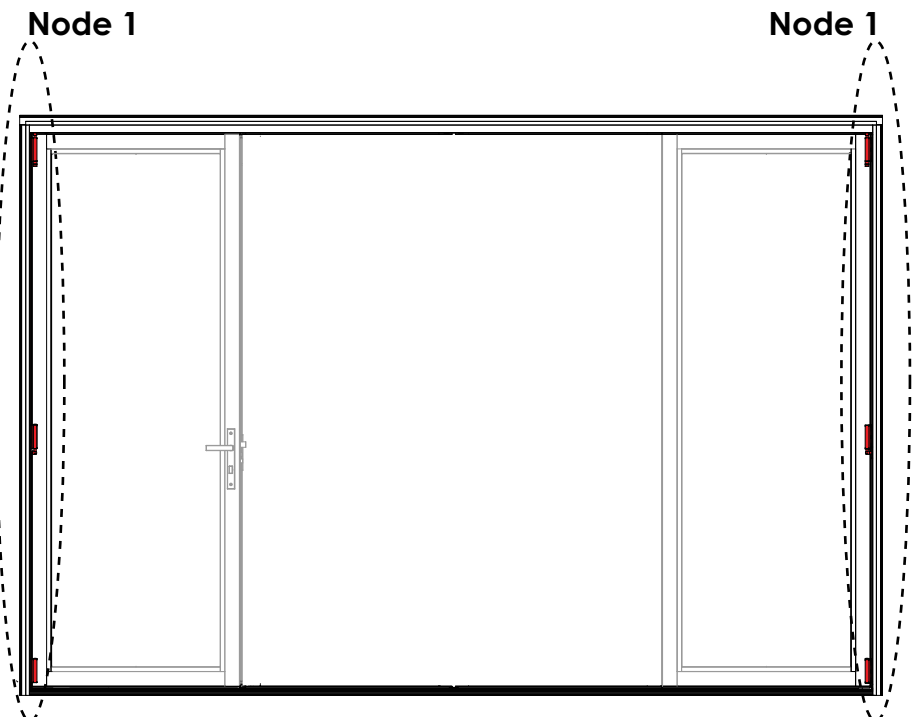
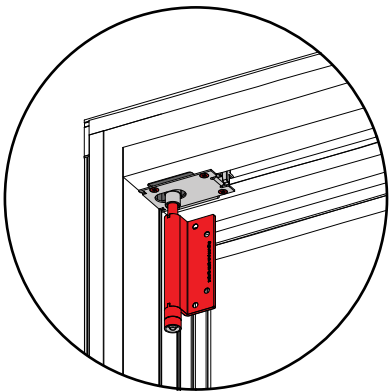
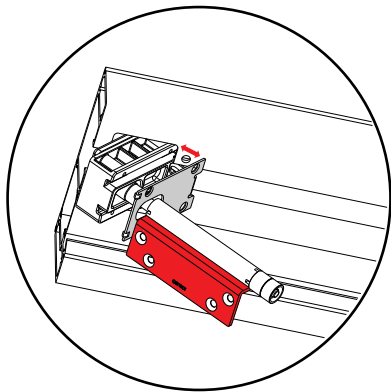

FIG 41

Continued on next page...



# STEP 5- PANEL INSTALLATION

## Node 1 Continued...

### Hardware installation at Node 1

Continue with the Pivot Jamb on the side where 2 or more panels collect in the door open position. Below are directions on how to install the Middle Hinge to the Jamb, and the Bottom Hinge to the sill.

**Important:** Check Hinge and if required change handing position per your model requirement. Instructions on how to change handing is available under Parts List. **[FIG 10]**

Install WPS Middle hinge on the Jamb. **[FIG 42]**

- o Check hardware handing position.
- o Apply the gasket from the WPS package to the baseplate.
- o Attach WPS Baseplate into Jam in the prefabricated hole provided.
- o Insert screws into the baseplate in the vertical position.
- o Attach Hinge Rod and prop it up against the wall of the Jamb for now.

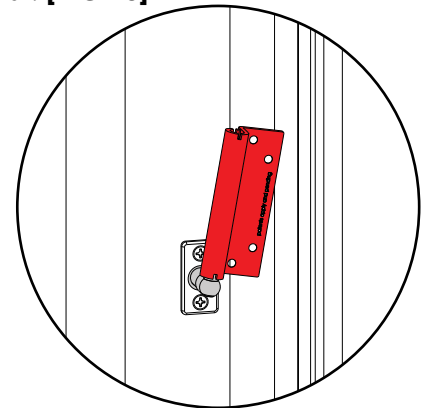

**FIG 42**

Install CPS Bottom hinge to the Sill. **[FIG 43]**

- o Check hardware handing position.
- o Insert Bottom Baseplate in the sill cavity. Use a pen to mark holes to predrill. Remove baseplate and drill holes marked in above step.
- Note:** Do not drill into the bottom Sill wall.
- o Attach Plastic Baseplate. Start by screwing the hole closest to the jamb first. Use **FA0442**.
- o Insert Pivot Rod into the Plastic Baseplate.
- o Snap adjustment screw cap onto the adjustment screw.
- o Install the adjustment screw all the way in and then back 5 counterclockwise turns.
- o Attach the baseplate down to the sill with the second screw. Use **FA0440**.



#8 x 1/2" | **FA0442**  
Drill bit size: 9/64"

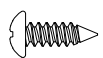

#8 x 5/8" | **FA0400**  
Drill bit size: 9/64"

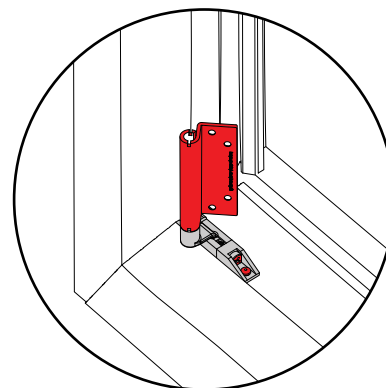
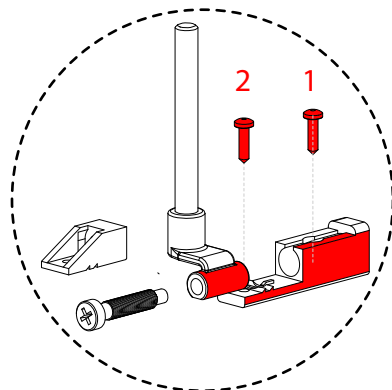

**FIG 43**

**Continued on next page...**



# STEP 5- PANEL INSTALLATION

## Node 1 Continued...

### Panel attachment at Node 1

Before installing Panel verify that CPS Top Hinge has been adjusted and installed in a Neutral Position and the handing is correct.

- From the exterior of the building, with the Glazing Bead of the panel to the exterior, Prop door 90 Degrees to the Jamb, use temporary support to adjust the height to align top hinge plate holes in door panel. **[FIG 44]**
- Screw CPS Top Hinge into door panel. Use **FA8609**.
- Slip hinge plate onto WPS rod ensuring correct handing and attach hinge plate to door panel. Use FA8609. Tap WPS top closure into the hinge lightly.
- Screw CPS Bottom Rod to attach hinge plate to door panel. Use **FA8609**.
- If panels are taller than 8' install additional Middle Hinge. Use box WPS.

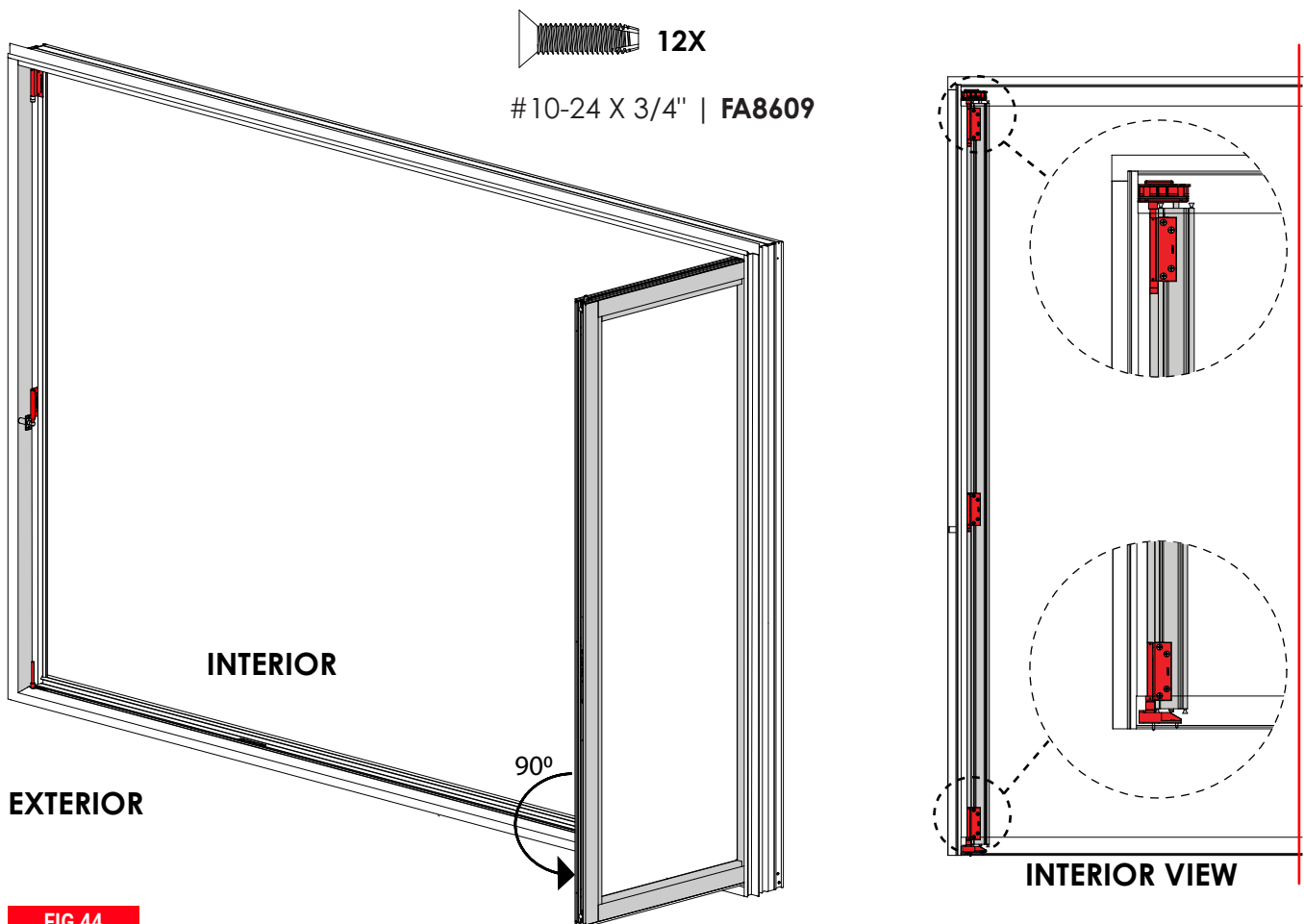

**FIG 44**



# STEP 5- PANEL INSTALLATION

## Node 2

### Panel attachment at Node 2

Depending on the Handing of your door, this step may be completed 1 or 2 times.

- Once the Node 1 hinges are installed, place first panel at 45° Angle from the Pivot Jamb. Use a temporary setting block and shims to support and hold the panel in this position. **[FIG 45]**
- From the exterior of the building, with the Glazing Bead of the panel to the exterior, place the next panel at 90° to the panel installed at Node 1.
- Use a setting block and shims under the second panel to keep the panel level.
- Complete installation of the set of hinges at **Node 2** that connect the 1st and the 2nd Panel. Use FA8609. **[FIG 46]**
- If panels are taller than 8' install additional Middle Hinge. You will use box HNH or HHH based on your Handing.
- Repeat steps for each remaining Node 2.

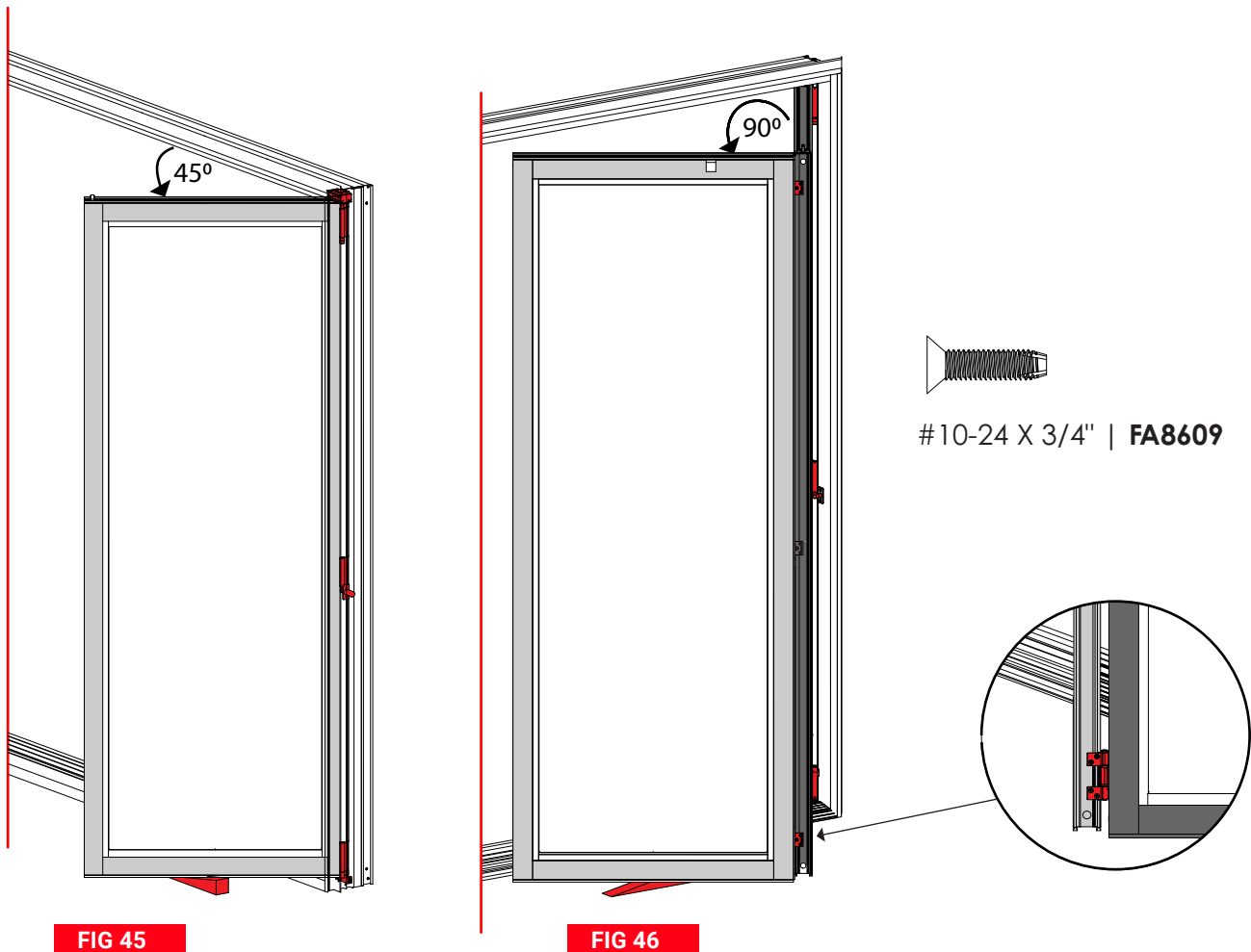



# STEP 5- PANEL INSTALLATION

## Node 3

### Panel attachment at Node 3

Depending on the Handing of your door, this step may be completed 1 or 2 times.

- Once the Node 2 hinges are installed, begin installation of the CIC Top Hinge. **[FIG 47]**
- From the Interior of the building, with the Glazing Stops on the panel to the exterior, attach the hinge to the panel loosely. Use **FA8609**. **[FIG 48]**
- Using the prefabricated pattern on the panel to align the holes to install the CIC Bottom Hinge.
- Install Middle hinge HNH at Node 3.
- If panels are taller than 8' install additional Middle Hinge. Use box HNH.
- If required, adjust the rollers until the edge of Intermediate Panel is parallel to the edge of the panel next to it and the gap at the Head and Sill is equal. Refer Page 38.
- Tighten all **FA8609** screws to secure the panel.
- Repeat steps for each remaining Node 3.



#10-24 X 3/4" | **FA8609**

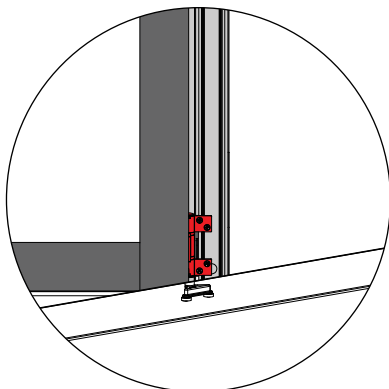
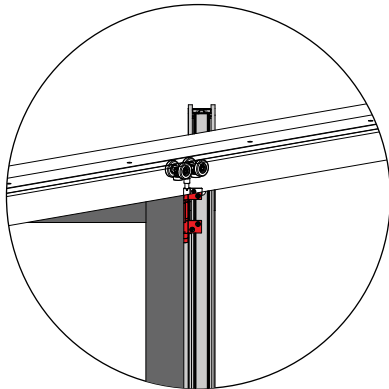

**FIG 47**

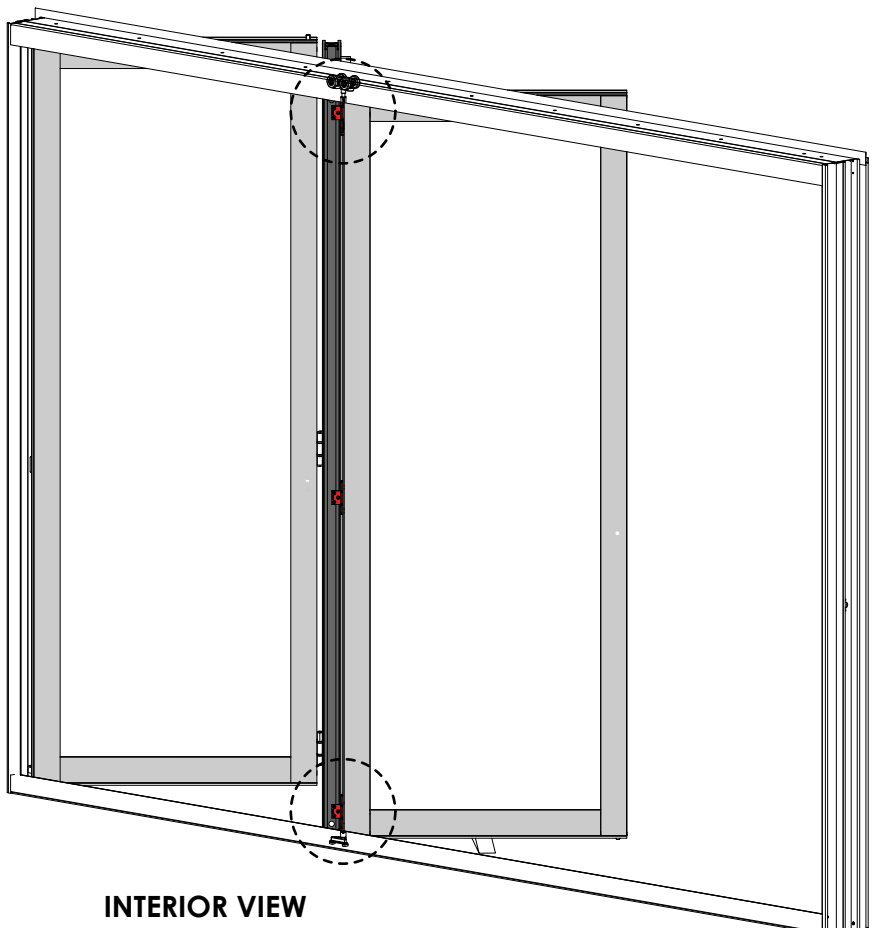

**INTERIOR VIEW**

**FIG 48**



# STEP 5- PANEL INSTALLATION

## Node 4

### ASTRAGAL Panel Installation

#### For 1L3R OR 3L1R MODELS

- Once last panel is attached to the intermediate hinge (Node 3), continue onto installing handle.

#### For 1L4R OR 4L1R MODELS, Use instructions below for Node 4

- Once the panel with the astragal is attached to the preceding panel at Node 3;
  - Remove the Astragal. Keep screws nearby for reattaching the Astragal. **[FIG 49]**
  - Attach the Top and Bottom End Carriers. Use CLC or CRC depending on door handing. **[Refer Page 25-26]**
  - Re-attach the Astragal back into the panel using the same screws. **[FIG 50]**
- Attach the Astragal Lock Strike. Use **HA0864** with **FA0181** screws. **[FIG 51]**

**Note:** The Shootbolt Handle will be attached to the panel in a following step.

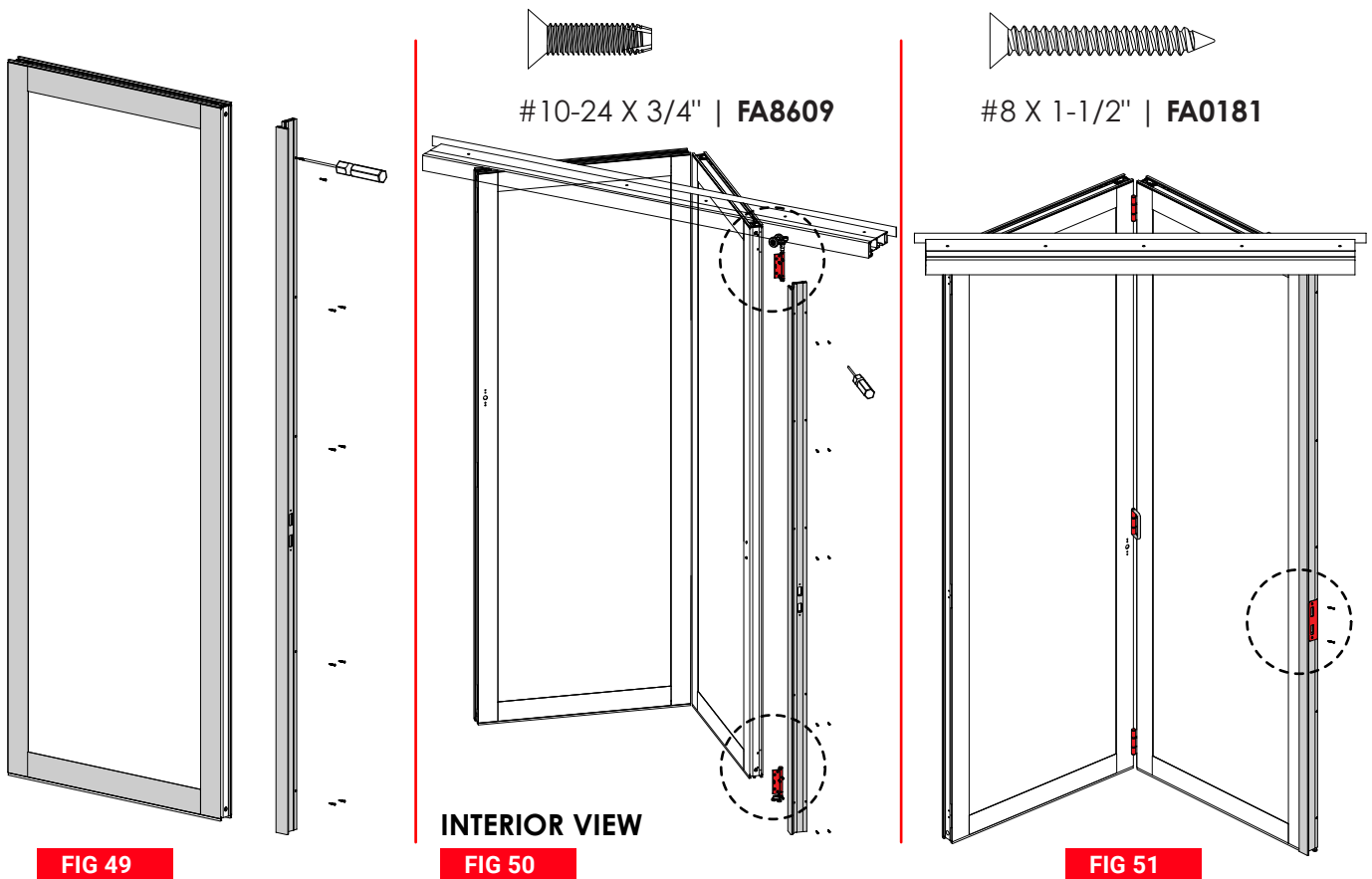

# STEP 5- PANEL INSTALLATION

## Panel Adjustment

### Horizontal Gap Adjustments

#### Horizontal Panel Adjustments [FIG 52]

- Door System with ENTRY DOOR - GAP 1, GAP 2 and GAP 3  
 On Handings where an Entry Door Panel meets a panel with an Astragal, the desired gap after adjustment is between 1/4" to 3/8".  
 Gaps at the Jamb must be equally distributed.  
**NOTE: This applies to 1L3R, 3L1R, 1L4R OR 4L1R**
  
- Door system without ENTRY DOOR - GAP 2 and GAP 3  
 On Handings with the panel locking into the Jamb, Gaps between the panel and the Jamb must be equally distributed.  
**NOTE: This applies to 0L3R, 3L0R, 0L5R OR 5L3R**

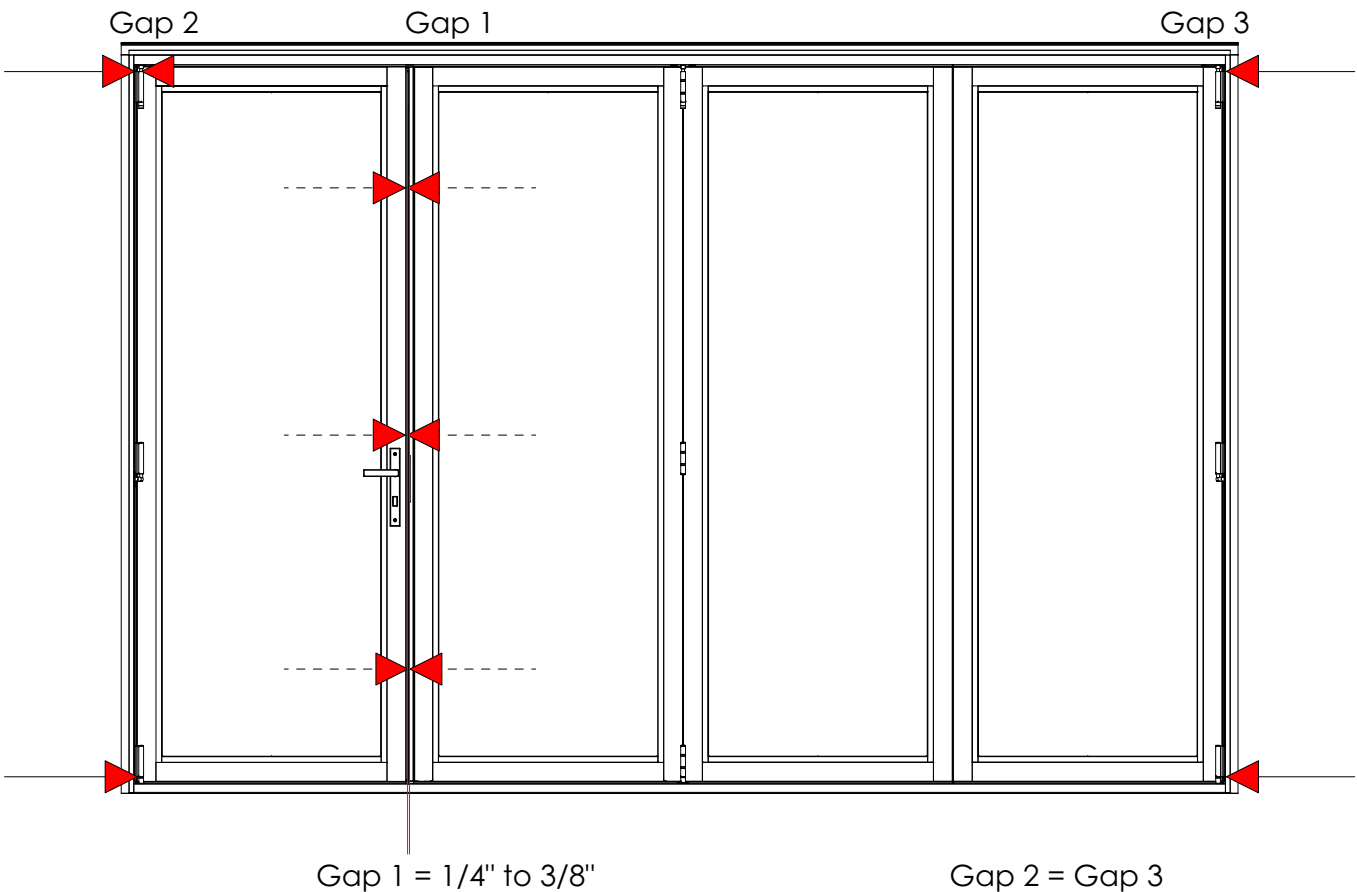

#### EXTERIOR VIEW

**FIG 52**



### Vertical Gap Adjustments

#### Vertical Panel Adjustments [FIG 53]

- Panel Gap on the TOP and Bottom of the Panels will be adjusted at each CPS, CLC, CRC and CIC. i.e. Node 1, Node 3 and Node 4 of all Door Handings.
- Gaps at the Top and Bottom must be equally distributed.  
GAP 4 = GAP 5

Use the next page to make adjustments to required measurements.

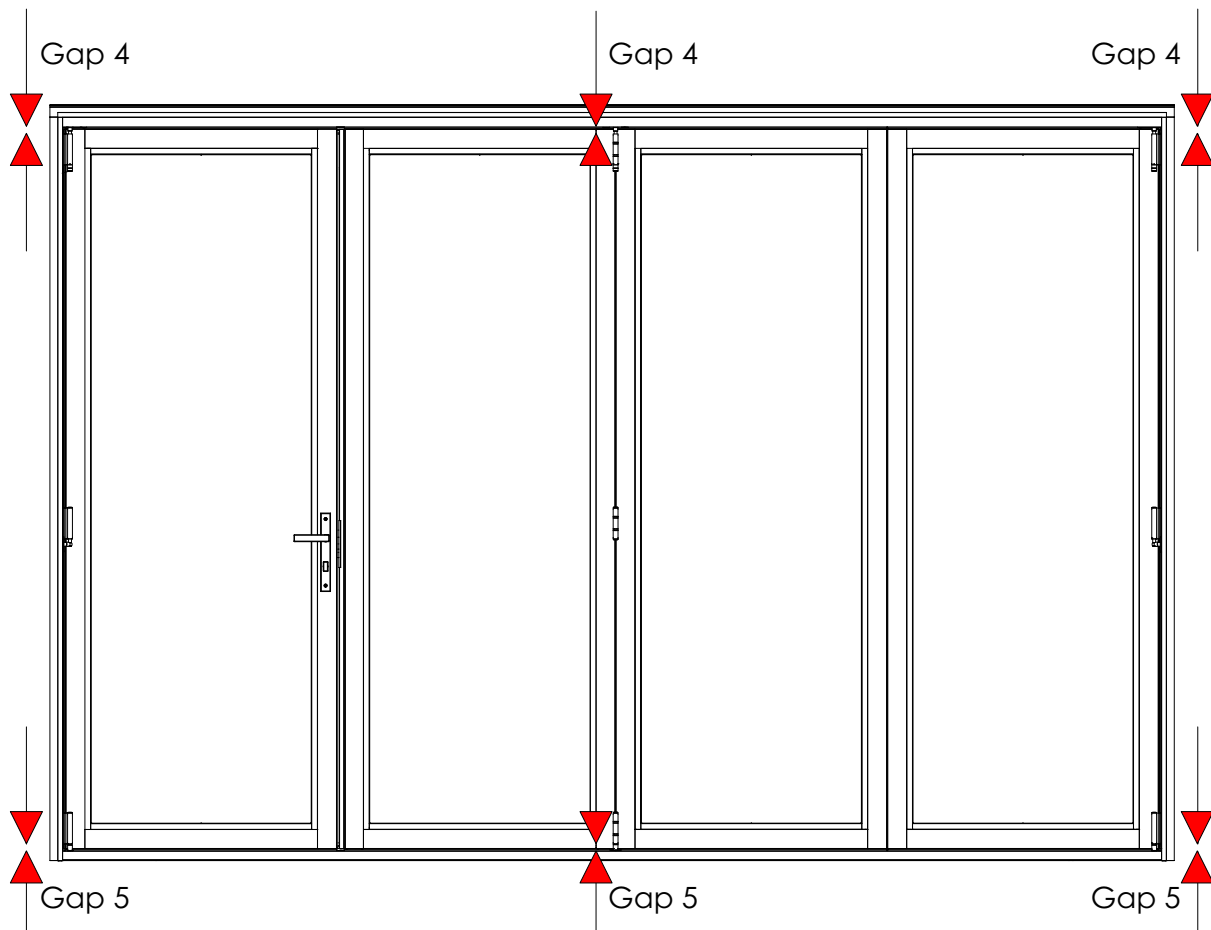

#### EXTERIOR VIEW

FIG 53



# STEP 5- PANEL INSTALLATION

## Panel Adjustment

### How to make adjustments

The steps below must be performed after ALL the panels have been installed. **[FIG 54]**

**A)** Adjust CPS and CIC vertically; Some Door Systems may use CRC or CLC. Insert a 5/16" (8 mm) Allen wrench into the bottom of the hinge.

Turn clockwise to raise the panel, turn counterclockwise to lower the Panel.

**Note:** The gap between the Panel and Jamb on each side should be equal, as referenced in the previous pages

**B)** Adjust CPS (TOP AND BOTTOM) horizontally;

Use a long Phillips head screwdriver. Turn the screw counterclockwise to move toward the Jamb and rotate it clockwise to move away from the Jamb.

**Note:** The gap between the Panel and Jamb on each side should be equal.

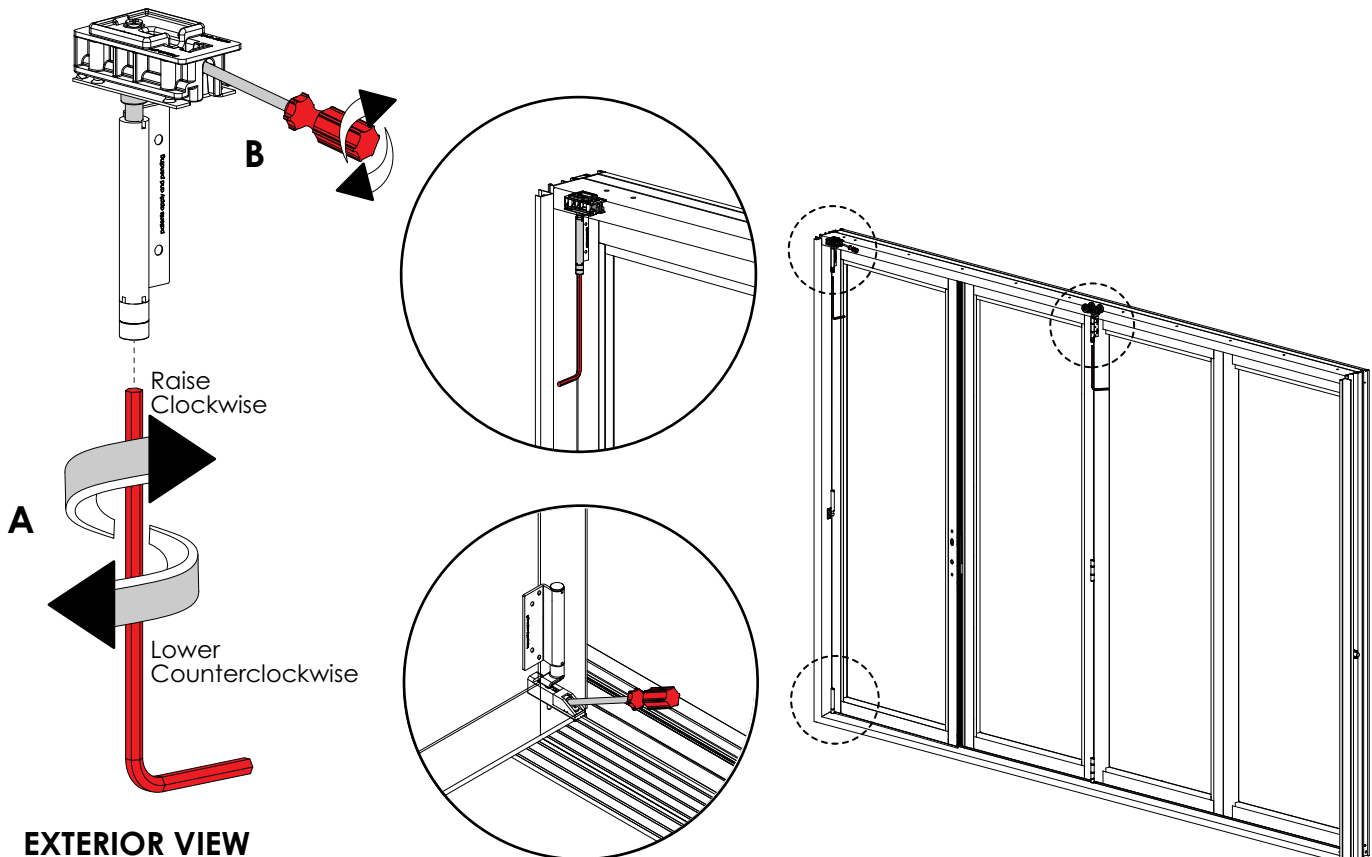

**EXTERIOR VIEW**

**FIG 54**





## STEP 6- ACCESSORY INSTALLATION

### Handle Installation

#### Entry Door Handle

Use Instructions provided with the Handle to install the Handle for the Entry Door.

1 per Door System.

#### Shootbolt Door Handle

Use Instructions provided with the Handle to install the Shootbolt Handle.

1 Shootbolt Handle will be installed at Node 2 of each Door System.

Additionally, for **1L3R, 3L1R**, 1 Shootbolt handle will be installed on the Panel with an Astragal.

#### Handle Lock Adjustment [FIG 55]

- o Check Handle Locking Tabs orientation. If required pull-out and turn the 2 Locking tabs in the correct position.

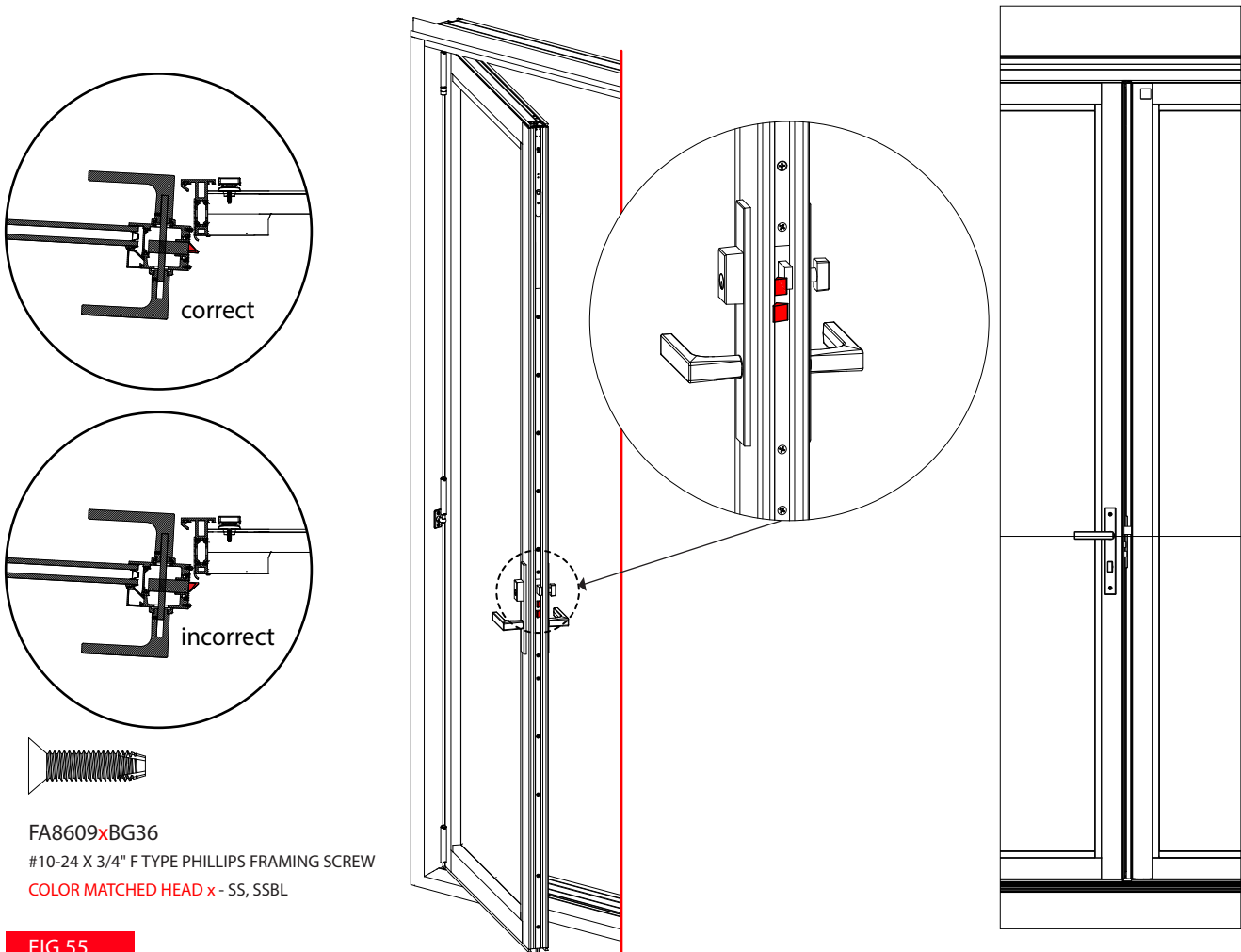

# STEP 6- ACCESSORY INSTALLATION

## Hinge Gasket

### Hinge Gasket Application

- Apply Hinge Gasket around all hinges. Use **SE8611**.
- Peel away the adhesive backing to stick the Gasket in the correct position.
- Each CPS (Top and Bottom) and WPS will receive a Hinge Gasket. **[FIG 56]**
- For Node 2 and Node 3 use 1 Hinge gasket at each hinge. The Gasket will be applied on the inside of the panel with 2 Hinge leaves. **[FIG 57]**

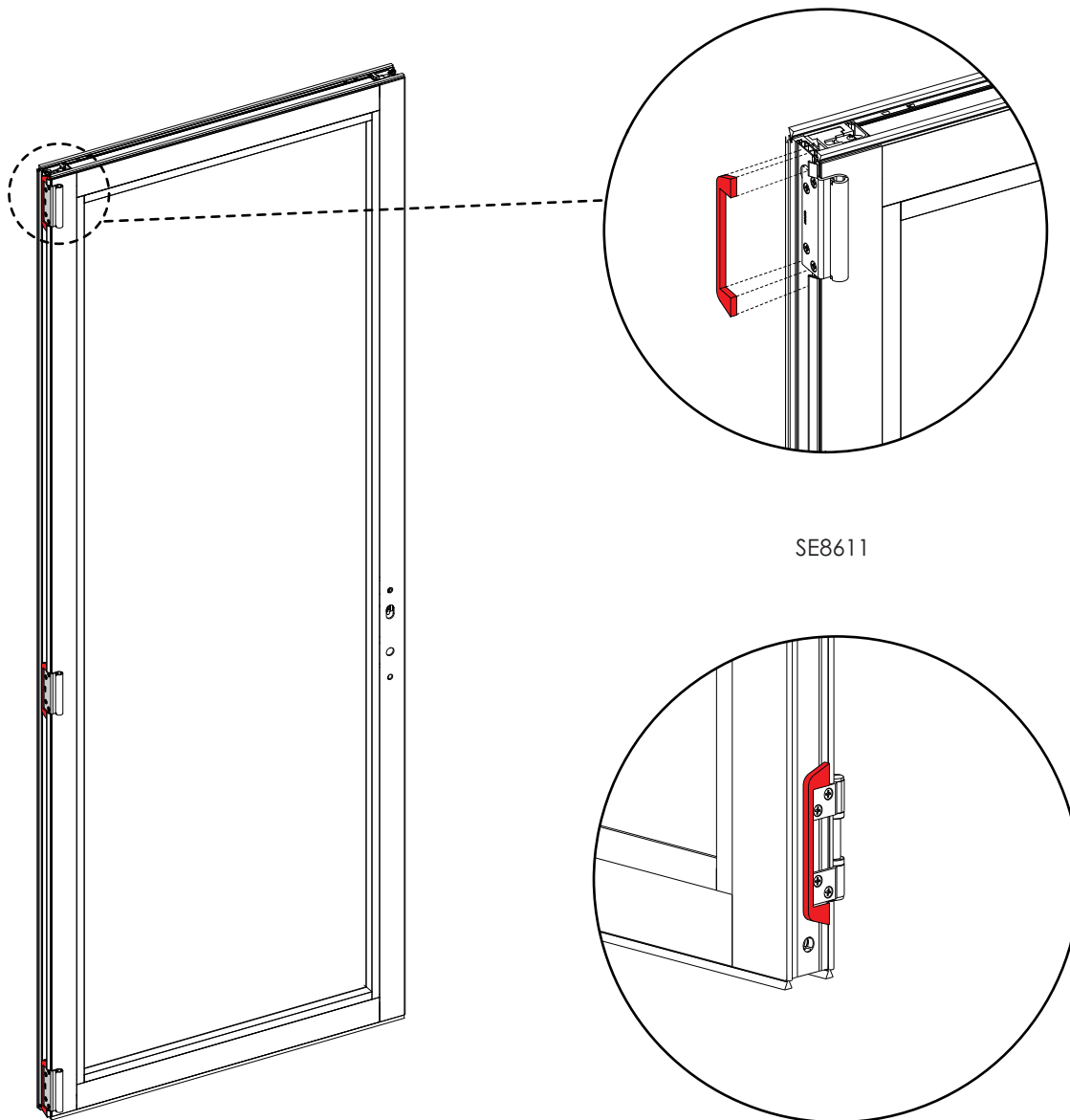

FIG 56

FIG 57



# STEP 6- ACCESSORY INSTALLATION

## DOOR HOLD (Magnets)

### Door Hold Location

Magnets will be placed differently based on the panel type. Measure, mark and then drill a single hole in the location indicated below.

- PANEL WITH HANDLE - Position A  
1 1/2" Distance from the top- edge and 10" from the side-edge of the panel.

**[FIG 58]**

**NOTE:** This applies to 0L3R, 3L0R, 0L5R OR 5L3R

- PANEL WITHOUT HANDLE - Position B  
1 1/2" Distance from the top- edge and 1 5/8" from the side-edge of the panel.

**[FIG 59]**

**NOTE:** This applies to 1L3R, 3L1R, 1L4R OR 4L1R

### Door Hold Installation

Use instructions below for PN: HA8638 magnet install **[FIG 60]**

- Unscrew baseplate from the magnet
- Attach the baseplate onto the panel in the hole you pre-drilled in the previous step. Use screw supplied with magnet.
- Align set screw hole horizontal and install set screw using 1/16" Allen wrench.
- Screw Magnet head on tight and parallel to the top- edge of panel.

Drill bit size: 11/64"

POSITION A

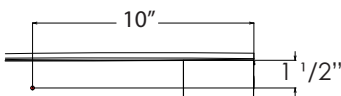

**FIG 58**

Drill bit size: 11/64"

POSITION B



**FIG 59**

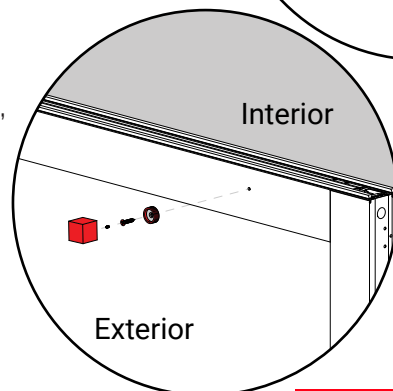
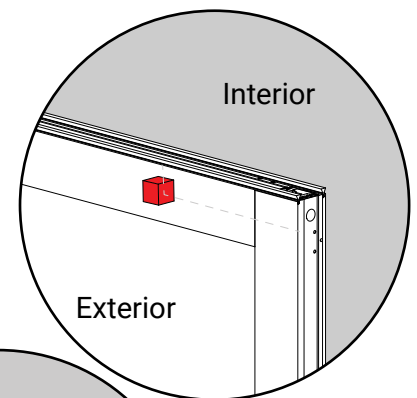

**FIG 60**





# STEP 6- ACCESSORY INSTALLATION

## DOOR HOLD (Magnets)

### IF USING HA8687 Magnet

#### Door Hold Location

Magnets will be placed differently based on the panel type. Measure, mark and then drill a single hole in the location indicated below.

- o PANEL WITH HANDLE - Position A  
1 1/2" Distance from the top- edge and one hole 11.2" from the side-edge of the panel and another 8.8" from the side-edge of the panel.  
[FIG 58]

**NOTE: This applies to 0L3R, 3L0R, 0L5R OR 5L3R**

- o PANEL WITHOUT HANDLE - Position B  
1 1/2" Distance from the top- edge and one hole 4" from the side-edge of the panel and another 1.6" from the side-edge of the panel.  
[FIG 59]

**NOTE: This applies to 1L3R, 3L1R, 1L4R OR 4L1R**

#### Door Hold Installation

Use instructions below for magnet install[FIG 60]

- o Remove magnet cover.
- o Place springs supplied with the magnet into holes located on the back side of the magnet.
- o Attach magnet onto the panel in the holes you pre-drilled in the previous step. Use FA0316SS screws supplied in the hardware kit.
- o Screw magnet head on tight and parallel to the top-edge of panel.
- o Replace magnet cover.

Drill bit size: 9/64"

POSITION A

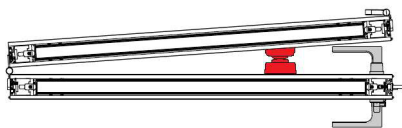

Drill bit size: 9/64"

POSITION B

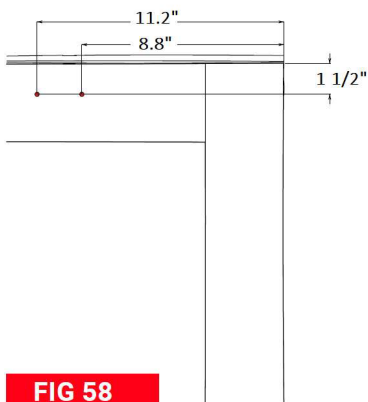

FIG 58

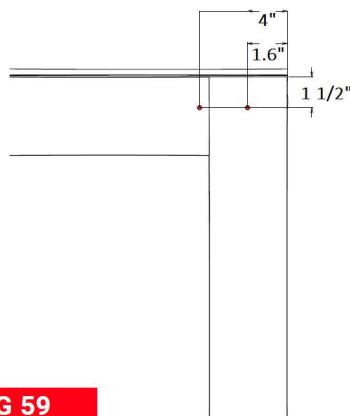

FIG 59

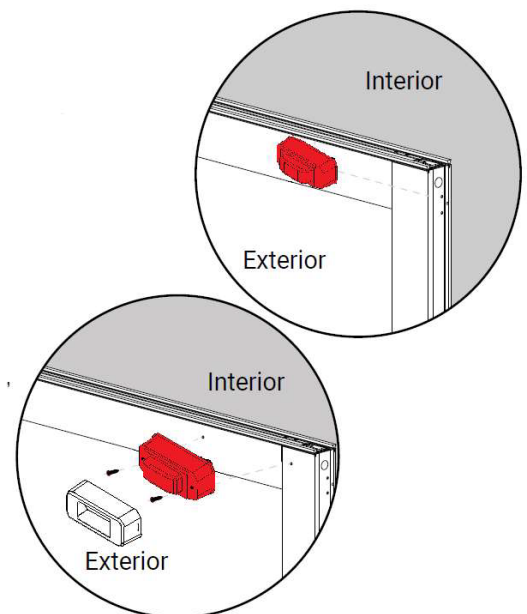

FIG 60





# Tall Door Reference Sheet

Door height > 8 feet.

## Additional Middle Hinge used for Doors Systems taller than 8'. [FIG 61]

Additional middle hinges are shipped loose in the Hardware Box.

- o At Node 1 the additional middle hinge used is WPS.
- o At Node 2 the additional middle hinge;  
HS uses HNH and HHS uses HHNH.
- o At Node 3 the additional middle hinge used with CIC is HNH.
- o At Node 4 the additional middle hinge used with CLC or CRC is HNH.

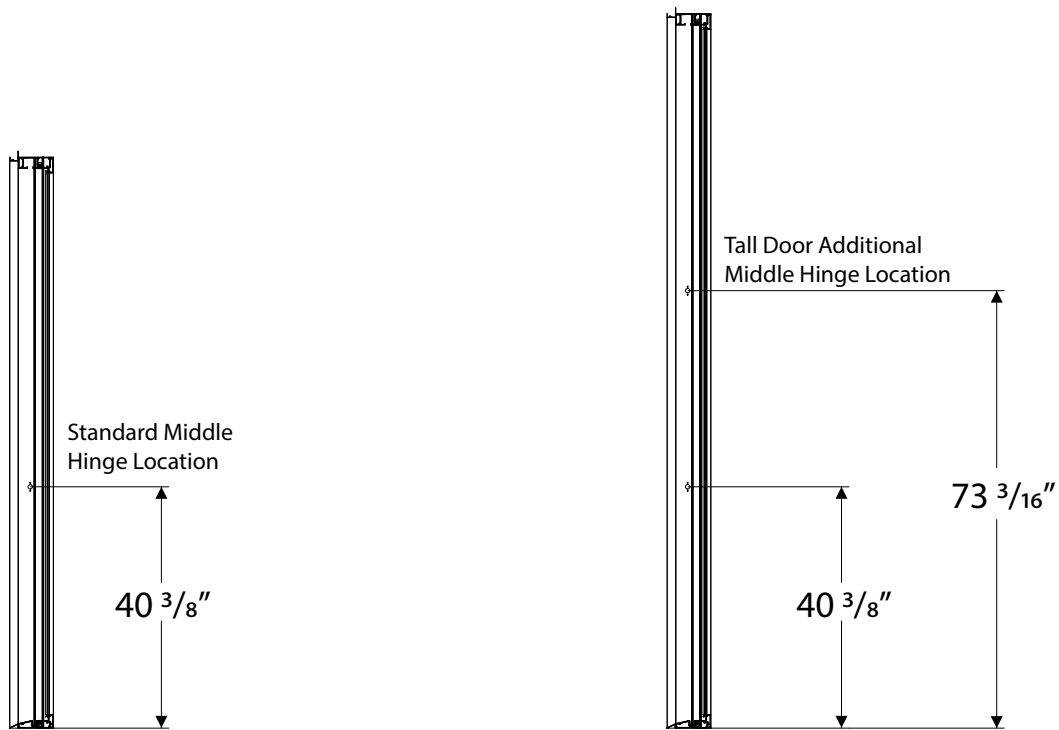

DOOR HEIGHT UNDER 8'

DOOR HEIGHT OVER 8'

SIDE VIEW

FIG 61

